

# Feasibility of ultrasound positioning based on signal strength

C.Medina, J.C.Segura

Dept. of Signal Theory, Networking and Communications  
CITIC-UGR, University of Granada  
C/Rafael Gómez Montero n2, E-18071, Granada, Spain  
cmedina@ugr.es, segura@ugr.es

S.Holm

Dept. of Informatics  
University of Oslo  
P.O.Box 1080, NO-0316, Oslo, Norway  
sverre@ifi.uio.no

**Abstract**—The objective of this paper is to analyze the performance of an indoor positioning system based on the ultrasound level, usually called RSSI (received signal strength indicator). This paper builds on past experiences where RSSI values from beams sent in different directions were compared [1]. There relative values of RSSI were measured but herein we go one step further and perform localization based on absolute values of RSSI. The use of RSSI could potentially mean a simplification of the traditional positioning systems design in relation to other methods such as TOF (time-of-flight), being an alternative and interesting method for positioning. The distance between nodes (transmitter and receiver) is estimated from RSSI values using a signal propagation model in which the power losses due to the spherical divergence and atmospheric absorption are considered. However, in real conditions, other factors related to the characteristics of the nodes have their impact on RSSI measurements. One of them has to do with the beamwidth of the transducers. The signal strength will be conditioned by the angle of incidence of the transducers when these have a narrow beamwidth. On the other hand, the common use of wireless nodes in the deployment of these systems leads to the RSSI measurement to be affected by the battery level in the nodes. These effects introduce significant errors in the distance estimation and therefore on the localization precision. Herein we propose a mechanism for modeling the power loss due to the orientation of the ultrasonic transducers, as well as an algorithm to compensate for the effect of the variations in the battery level on RSSI measurements. Some experimental results have been obtained with 5 nodes (4 transmitters and 1 receiver) to show the quality of our compensation using a real positioning system. Location errors smaller than 10 cm for each coordinate are obtained in contrast to errors of several meters which are normally attained in this kind of systems based on RF (radio frequency) RSSI-values.

**Keywords**- *Signal strength; Ultrasound; Positioning; Battery level; Angular dependence*

## I. INTRODUCTION

Currently most local positioning systems (LPSs) are based on wireless sensor networks (WSNs). The WSNs have a low cost, offer scalability and also an easy deployment of location systems. These systems use typically a radio interface to allow

the communication between the nodes of the network. This infrastructure can also be used to provide localization using the RSSI measurements of the radio packages.

Radio protocols such as ZigBee allow one to measure easy the RSSI value of the radio packages. From this value, the distance between a transmitter node and a receiver node can be estimated using propagation models. However, the confinement problem of the RF signals and the difficulty to model their propagation, leads to important errors in positioning. These errors are typically of several meters, which are unacceptable for indoor location applications. In a building, for example, the mobile node could be located in another room or even another floor.

Other technologies such as infrared or ultrasound are typically used to achieve greater precision. Using such technologies, a target can be located with guarantees in an enclosed space due to the confinement of these signals. The reflections of the infrared signal are unlikely, so that the RSSI measurement requires a direct line of sight between the transmitter and receiver devices. On the other hand, this signal may be disturbed by the sun light and fluorescent light. By contrast, the ultrasound signal is immune to these interferences and allows multiple reflections, so it does not require a direct line of sight between the nodes to detect signal. This allows the use a smaller number of sensors to detect the presence of a target in a closed environment. By ignoring the signal path, some problems such as partial obstructions and other factors that affect the RSSI measurements are solved. Thus, these features favor the use of ultrasound signals rather than infrared signals.

If there is a direct line of sight between emitter and receiver or the path of signal propagation is known, then it is possible to estimate the distance between them from RSSI measurements using an ultrasound propagation model. Although the location precision is significantly better than that obtained with measurements based on RSSI-RF, such precision is still insufficient for location applications where errors of few centimeters are required. In this sense, it is common take advantage of the slow speed of propagation of ultrasonic signal to estimate its time-of-flight (TOF) between a transmitter node and a receiver node. The TOF measurement is then used to

calculate the distance value between nodes considering the propagation speed of sound. The TOF of ultrasound signal enables us to estimate distances with a precision of centimeters or even millimeters [3]. This precision may be useful for certain applications (e.g., industrial applications). However, for everyday location applications a precision of tens of centimeters is often sufficient. The TOF measurement requires a precise synchronization of the nodes to achieve good accuracy. This synchronization is particularly complex in WSNs where it is necessary to apply compensation algorithms to solve problems such as the clock drift at the nodes [2]. In addition, the TOF measurement requires advanced digital signal processing techniques which imply more hardware resources in the design of the nodes and a higher cost of the system.

In this paper we propose to use the ultrasonic RSSI measurement to determine the position of a mobile node with an acceptable precision for most daily location applications. We think that RSSI is an alternative method for positioning which includes simplicity of development and lower cost. This paper builds on past experience where RSSI values from beams sent in different directions were compared [1]. There relative values of RSSI were measured but in this paper we go one step further and perform localization based on absolute values of RSSI.

The received signal might have followed a non-direct path due to partial obstructions in the signal path or an inadequate orientation of the transducers, causing a poor estimate of distance. However, the RSSI measurement allows knowing the approximate position of the mobile node when this happens (e.g. the room in which it is located). The use of RSSI measurement instead of TOF measurement could potentially mean a simplification of the system design, a lower cost of signal processing and therefore a lower consumption.

However, to achieve an acceptable precision using RSSI measurement, two fundamental problems that typically occur in this type of systems must be solved. One of them has to do with the orientation of ultrasonic transducers, where their directional characteristics determine the emitted and received signal strength. The other problem is the voltage loss of batteries due to the consumption of the node, thus affecting the RSSI measurement.

The paper is organized as follows. In Section II we present a propagation model of ultrasound signal to estimate the distance from RSSI measurements, where losses by spherical divergence and atmospheric absorption are considered. In Section III, the effect of the ultrasonic transducer orientation is analyzed, and the function that allows one to model the losses by orientation to correct the RSSI measurement is reported. Section IV shows the effect of battery voltage on the RSSI measurement and the algorithm to compensate for this effect. In Section V, the improvement in the distance estimation by considering our approaches is shown. There some location results when these compensations are applied to the RSSI measurements are also shown. These results are obtained using the TELIAMADE system [3] in controlled scenarios where orientation and battery effects appear. Finally, in section VI, we summarize the main conclusions of this work.

## II. LOCATION BASED ON ULTRASOUND-RSSI MEASUREMENTS

In this paper we use the TELIAMADE system [3] for carrying out the evaluation of our approaches. The TELIAMADE system is based on a wireless network of smart nodes. Network architecture is based on the ZigBee protocol which fits the low power requirements for the smart sensor network design. A star network topology is used with a network coordinator and a set of end nodes. End nodes are equipped with a low power microcontroller (PIC18F4620) [4], and a radio chip (CC2420) [5] implementing the 802.15.4 physical layer. The rest of the ZigBee stack is implemented by software in the microcontroller. Each TELIAMADE node is also equipped with a couple of low cost ceramic ultrasonic transducers (400ST/R120) [6] with a center frequency of 40 kHz and a 6 dB bandwidth of 2 kHz. Therefore, a given node can be configured to transmit or receive an ultrasonic signal at a given time. Fig. 1 summarizes the operation of the TELIAMADE system in its typical configuration. The devices located on the ceiling (denoted by Tx) represent the end nodes configured as ultrasonic transmitters. The mobile node (denoted by Rx) is configured as ultrasonic receiver. The configuration and control of the network nodes is done by sending of radio packets issued from the coordinator node. The RSSI measurements between a transmitter node and a receiver node are returned to the coordinator for determination of the receiver node position. However, the current configuration of the system can be modified so that the receiver node can perform this estimation using the hardware resources available.

RSSI estimations are obtained by measuring the amplitude of an ultrasonic pulse of  $T_b$  duration, between a pair of nodes; one acting as an ultrasonic transmitter and the other as an ultrasonic receiver. The ultrasonic burst generation is performed by the EUSART (enhanced universal synchronous asynchronous receiver transmitter module) of the microcontroller. A sequence of alternating 0 and 1 bits is generated at a baud rate of twice the nominal transducer frequency (i.e. 80 kbps) with an appropriate length (e.g. a pulse of 1 ms requires the transmission of a sequence of 80 alternating bits). The EUSART output is buffered through a digital inverter gate (74HC04) [7] to provide the needed current gain to drive the ultrasonic transducer. In reception, the signal is amplified and band-pass filtered before being sampled and digitized, using the A/D converter of the microcontroller with 10-bit resolution for a suitable dynamic range. This signal conditioning stage is implemented using a dual operational amplifier (LMC6482) [8] and some passive components (resistors and capacitors). TELIAMADE nodes are battery powered, with a voltage between 2.7 and 3 volts. Fig. 2 shows the block diagram of the designed module for transmission and reception of ultrasonic signals. Details signal conditioning in transmission and reception are shown. In reception, the signal processing for the RSSI measurement is briefly indicated. A detailed description of such processing is presented in subsection II-A.

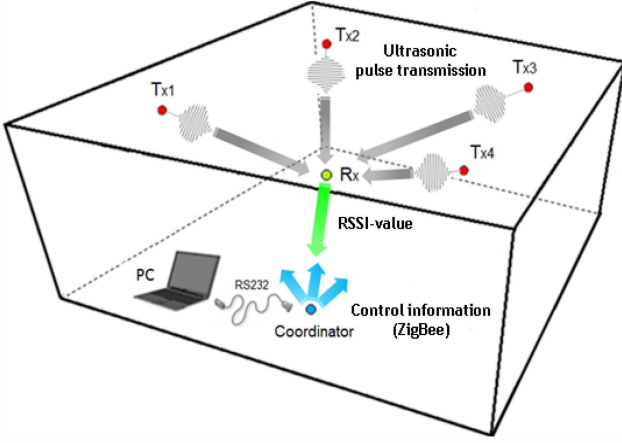

Figure 1. Typical configuration of the TELIAMADE system. A coordinator node is connected to a PC through which all other nodes of the network are managed. A set of fixed nodes work as ultrasonic transmitters (Tx) and are placed in known positions (typically on the ceiling). The mobile node to be located operates as ultrasonic receiver. Its position is determined by applying multilateration from the estimated distances to the transmitter nodes. A propagation model is used for this purpose considering RSSI values.

The picture of a TELIAMADE node is shown in Fig. 3, where it identifies the hardware components of the radio module and the transmission and reception modules of ultrasonic signal.

#### A. Estimation RSSI-value

Computation of the RSSI is performed by the receiver node using a quadrature digital correlator. A band-pass sampling scheme [9] is used to reduce the required memory and processing resources. The signal is sampled at the receiver using a sampling frequency ( $F_s$ ) [10] given by

$$F_s = \frac{4F_0}{(2M-1)}, \quad (1)$$

where  $F_0$  is the carrier signal frequency (40 kHz) and  $M$  is an integer. The sampling frequency must satisfy the constraint of  $F_s \geq 4B$ , where  $2B$  is the signal bandwidth (double sideband). Then the quadrature sampling allows one to use relatively low sampling frequencies of the order of 17.78 kHz ( $M=3$ ) or even 12.31 kHz ( $M=5$ ), so that memory resources and computational cost in signal processing are reduced.

Equation (2) shows the expression for a band-pass signal using digital quadrature sampling which allows one to extract samples of the in-phase component ( $I(n)$ ) and quadrature component ( $Q(n)$ ) to a frequency of  $F_s/2$ .

$$x(n) = I(n) \cos\left(\pi n \left(M - \frac{1}{2}\right)\right) - Q(n) \sin\left(\pi n \left(M - \frac{1}{2}\right)\right). \quad (2)$$

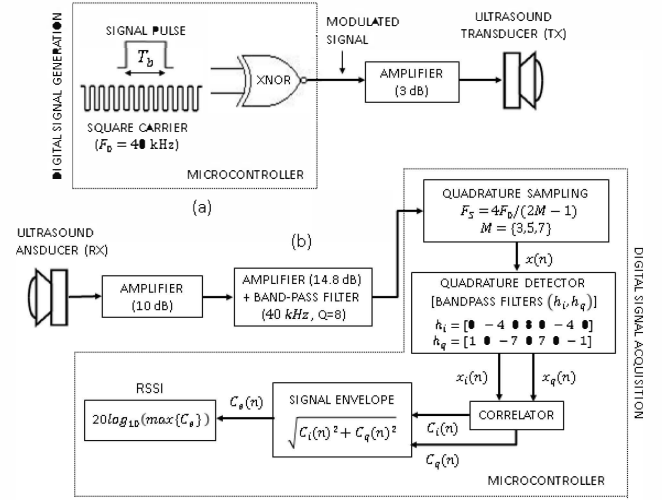

Figure 2. Block diagram of the designed module for transmission (a) and reception (b) of ultrasonic signal in a TELIAMADE node. In transmission, the signal is amplified before being driven to the transducer, in order to increase the signal power and improve the range of the system. In reception, the signal is amplified and band-pass filtered before being sampled and digitized using the A/D converter of the node's microcontroller. The computation of the RSSI is performed using a quadrature digital correlator (see subsection II-A).

Due to interleaved sampling, the samples  $I(n)$  are only known at even values of  $n$ , while samples  $Q(n)$  are known at odd values of  $n$ . However, since the signals are properly sampled,  $I(n)$  and  $Q(n)$  can be recovered to a sampling frequency of  $F_s$  (i.e. at the same instant) using an interpolation process. To this end, two band-pass quadrature filters are used to determine the values of the in-phase and quadrature components at the instants where they are unknown. Table I shows the way in which the in-phase and quadrature components are obtained by interpolation for an odd value of  $M$ . The parameter  $m$  of the table represents the sample index  $n$  expressed as module 4.

TABLE I. INTERPOLATED IN-PHASE AND QUADRATURE COMPONENTS FOR  $M$  ODD.

| Comp.        | $m=0$     | $m=1$     | $m=2$     | $m=3$     |
|--------------|-----------|-----------|-----------|-----------|
| $\hat{I}(n)$ | $+x_i(n)$ | $+x_q(n)$ | $-x_i(n)$ | $-x_q(n)$ |
| $\hat{Q}(n)$ | $+x_q(n)$ | $-x_i(n)$ | $-x_q(n)$ | $+x_i(n)$ |

where  $x_i(n)$  and  $x_q(n)$  are given by the following expressions:

$$x_i(n) = 8x(n) - 4(x(n-2) + x(n+2)) \quad (3)$$

$$x_q(n) = 7(x(n+1) - x(n-1)) + x(n-3) - x(n+3).$$

From these in-phase and quadrature components, the outputs of the digital signal correlator are given by

$$C_i(n) = \sum_{k=0}^{K-1} \hat{I}(n-k) \quad C_q(n) = \sum_{k=0}^{K-1} \hat{Q}(n-k), \quad (4)$$

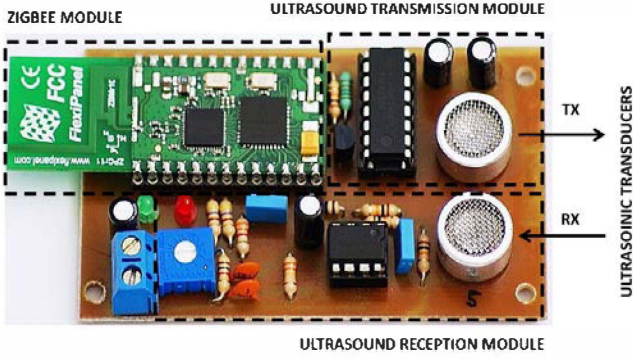

Figure 3. Picture of a TELIAMADE node. The regions identified by dashed line show the hardware components of the radio module and the signal conditioning modules for transmission and reception of ultrasonic signal.

where  $K = T_b F_s$  is the number of samples of ultrasonic pulse and  $T_b$  is the pulse duration. The signal envelope is calculated as

$$C_e(n) = \sqrt{C_i^2(n) + C_q^2(n)}. \quad (5)$$

Finally the ultrasonic RSSI-value is estimated by detecting the maximum of the envelope

$$RSSI = 20 \log_{10}(\max(C_e)). \quad (6)$$

### B. Using RSSI-value for location

A simple way to determine the position of the mobile node using RSSI is to construct a map of RSSI values of the localization environment. This involves taking a large number of measurements at different reference points. The position of the mobile node is estimated by comparing the current RSSI-value with other RSSI values measured at different reference points. However, this approach is not viable for location in large spaces or when a high precision is required due to the considerable workload that this implies.

A more efficient solution is based on predicting the distance between nodes (transmitter and receiver) by applying a propagation model for the ultrasonic signal. The mobile node position can then be calculated from the estimated distances to transmitter nodes using multilateration. The distance between nodes is obtained using the passive sonar equation in a way similar to that described in [11]:

$$\widehat{RSSI} \cong RSSI_0 - PL, \quad (7)$$

where  $\widehat{RSSI}$  is the estimated power level to any distance ( $R$ ),  $RSSI_0$  is the measured power level to a known distance ( $R_0$ ) (under reference conditions of temperature and relative humidity). In (7) we assume  $\widehat{RSSI} > (NL + DT)$ , where  $NL$  is the Noise Level and  $DT$  is the minimum Detection Threshold of signal. The term  $PL$  is the Power Loss due to the signal propagation. In this paper we use propagation model which includes both losses due to spherical divergence and atmospheric absorption. Its expression is given by

$$PL = 20 \log_{10}(R/R_0) + \alpha R, \quad (8)$$

where  $R$  is the real distance between a transmitter node and the receiver node and  $\alpha$  is the atmospheric absorption factor [12]. The following expression shows the dependence of  $\alpha$  (in Np/m) with the temperature  $T$  (in K), the relative humidity  $h$  (in %), the signal frequency  $f$  (in Hz) and the atmospheric pressure  $P_s$  (in atm).

$$\alpha = F^2 \frac{P_s}{P_{s0}} \cdot \left[ 1.84 \cdot 10^{-11} \left( \frac{T}{T_0} \right)^{\frac{1}{2}} + \left( \frac{T}{T_0} \right)^{-\frac{5}{2}} \left( 0.01278 \frac{e^{-\frac{2239.1}{T}}}{F_{r,O} + \frac{F}{F_{r,O}}} + 0.1068 \frac{e^{-\frac{3352}{T}}}{F_{r,N} + \frac{F}{F_{r,N}}} \right) \right], \quad (9)$$

with  $F = f/P_s$ ,  $F_{r,O} = f_{r,O}/P_s$  and  $F_{r,N} = f_{r,N}/P_s$ . The terms  $f_{r,O}$  and  $f_{r,N}$  are respectively the relaxation frequencies of oxygen and nitrogen whose value depends on the relative humidity and temperature. All the frequency terms in (9) are expressed in Hz.

The distance measurement  $R$  can be estimated by equating to zero the passive sonar equation (7) and substituting (8)

$$\Delta = (RSSI_0 - \widehat{RSSI}) - 20 \log_{10} \left( \frac{R}{R_0} \right) + \alpha(R - R_0). \quad (10)$$

The derivative of (10) with respect to  $R$  is

$$\frac{\delta \Delta}{\delta R} = -\frac{20}{R \log(10)} - \alpha. \quad (11)$$

From (10) and (11) the value of  $R$  is estimated using the Newton-Raphson iterative method for the initial approximation  $R = R_0$

$$R = \hat{R} - \frac{\Delta}{\delta \Delta / \delta R}. \quad (12)$$

For a typical scenario with one mobile node and a set of fixed transmitter nodes, the mobile position can be calculated by multilateration using the estimated distances to each transmitter node. These distances are denoted by  $R_i$ , where the subscript  $i$  refers to each transmitter node and takes values within the range  $i=1 \dots N$ , where  $N$  is the total number of transmitter nodes. The position of these nodes is known and it is denoted by its coordinates  $(x, y, z)$  in the form  $(t_{ix}, t_{iy}, t_{iz})$ . The position vector of the mobile node ( $m$ ) is calculated by solving an overdetermined system of linear equations given by the following expression

$$A \cdot m' = b \quad (13)$$

where

$$A = \begin{bmatrix} t_{1x} - t_{2x} & t_{1y} - t_{2y} & t_{1z} - t_{2z} \\ t_{1x} - t_{3x} & t_{1y} - t_{3y} & t_{1z} - t_{3z} \\ t_{1x} - t_{4x} & t_{1y} - t_{4y} & t_{1z} - t_{4z} \\ \vdots & \vdots & \vdots \\ t_{1x} - t_{Nx} & t_{1y} - t_{Ny} & t_{1z} - t_{Nz} \end{bmatrix}$$

$$b = \begin{bmatrix} 0.5(t_{1x}^2 - t_{2x}^2 + t_{1y}^2 - t_{2y}^2 + t_{1z}^2 - t_{2z}^2 + R_2^2 - R_1^2) \\ 0.5(t_{1x}^2 - t_{3x}^2 + t_{1y}^2 - t_{3y}^2 + t_{1z}^2 - t_{3z}^2 + R_3^2 - R_1^2) \\ 0.5(t_{1x}^2 - t_{4x}^2 + t_{1y}^2 - t_{4y}^2 + t_{1z}^2 - t_{4z}^2 + R_4^2 - R_1^2) \\ \vdots \\ 0.5(t_{1x}^2 - t_{Nx}^2 + t_{1y}^2 - t_{Ny}^2 + t_{1z}^2 - t_{Nz}^2 + R_N^2 - R_1^2) \end{bmatrix}.$$

A closed solution for  $m$  can be obtained using the least squares method. Solving for  $m$ , we have

$$m = ((A' \cdot A)^{-1} \cdot A' \cdot b)'. \quad (14)$$

However, factors such as the orientation of the transducers or variations in battery level of the nodes will influence the RSSI measurement. To compensate for these losses and reduce the localization error due to an incorrect estimation of distance, the RSSI expression is rewritten as

$$\widetilde{RSSI} = \overline{RSSI} + (\Delta_\theta)_{dB} + (\Delta_v)_{dB}, \quad (15)$$

where  $\Delta_\theta$  is the loss factor due to the orientation of the transducers and  $\Delta_v$  is the loss factor due to changes in the battery voltage. The following sections III and IV describe the form in which  $\Delta_\theta$  and  $\Delta_v$  are estimated.

### III. RSSI LOSS DUE TO ORIENTATION OF TRANSDUCERS

Most of ultrasound-based localization systems make use of narrowband transducers. These transducers are characterized by a high emission power and high sensitivity. These features allow good accuracy in the RSSI measurement and a long distance range. However, they have usually a highly directional radiation pattern with a beamwidth less than  $\theta = \pm 40^\circ$  as defined by 6 dB power loss. Therefore, variations in the orientation of the transducers will affect the RSSI measurement and thus the distance estimation. The power loss by orientation will be different depending of the transducer's features. In this paper we propose a theoretical model to estimate the power loss due to the orientation angle of the transducers. This model considers the transducer surface as an uniform circular aperture [13]

$$f(\theta) = (1 + \cos \theta) \cdot \frac{J_1(2\pi u)}{2\pi u}$$

$$\text{with } u = \frac{a}{\lambda} \sin \theta. \quad (16)$$

Equation (16) is the well-known Airy pattern for a circular aperture multiplied by an obliquity factor  $(1 + \cos \theta)$ . The term  $a$  is the radius of the circular aperture and its value is

approximated considering the resonance membrane radius ( $a$ ) of the transducer. In this case  $a=3.6$  mm, which is measured using a digital caliper. The parameter  $\theta$  is the angle of incidence of the transducer, and  $J_1(x)$  is the Bessel function of the first kind and order 1. The function  $f(\theta)$  is normalized to unity at  $\theta=0^\circ$  (easily seem as  $J_1(x)$  behaves like  $J_1(x) \cong x/2$  for small  $x$ ). The obliquity factor is a mix of the factor for a hard baffle and a soft baffle. This mixed obliquity factor is often found to describe practical ultrasound transducers quite well. From (16), the loss factor by orientation is found from the angle of incidence for the transmitter and for the receiver as

$$\Delta_\theta = |f(\theta_{tx})| \cdot |f(\theta_{rx})|. \quad (17)$$

In practice it is rather cumbersome to account for the loss factor as the two angles need to be found. In a future system we would therefore like to get rid of this factor, i.e. to use omnidirectional transducers. This is feasible for the receiver as there exist MEMS-based sensors which are intrinsically omnidirectional. However, care must be taken when they are mounted in a system as there must be no shadowing from the mounting or the printed circuit board.

The way to get an omnidirectional transmit transducer is to make the active radius  $a$  smaller. As we are not aware of any such transducer which is readily available now, one could instead use multiple transmitter transducers. For instance four transmitters spaced  $90^\circ$  apart could be used combined with a measurement of the response for each one in turn. This could give enough information to resolve the effect of the transmitter's angle of incidence. The disadvantage is the reduced update rate as four times, as many transmit pulses need to be sent.

The orientation problem is well known in WLAN-based fingerprinting positioning systems also where it is presently not corrected for [14].

### IV. RSSI LOSS DUE TO BATTERY CONSUMPTION

Nodes in wireless sensor networks (WSNs) are often powered by batteries. Depending of their configuration and workload, the consumption of batteries can be greater or less, causing voltage differences between network nodes. A reduction of the voltage level in the nodes affects the RSSI measurement. A lower voltage in the transmitter nodes results in a smaller signal gain at the output of the amplifier stage. On the other hand, a voltage drop in receiver node leads to a reduction of the dynamic range of the A/D converter, then the received signal is detected with an amplitude greater than its actual value and therefore with greater power.

Using the propagation model described in Section II, the distance between nodes can be estimated considering a reference power value  $RSSI_0$  measured to a fixed distance  $R_0$  under known atmospheric conditions of temperature and relative humidity. Since the RSSI measurement is conditioned by battery level of the nodes, the battery level must be considered in the  $RSSI_0$  estimation. The conditions under which  $RSSI_0$  is estimated are known as reference conditions. Therefore, since voltage conditions in the nodes may differ

from the reference conditions, the RSSI measurements will be affected by such variations.

A voltage drop in the transmitter batteries causes a lower RSSI value, and thus the estimated distance is higher than expected. This is due to the fact that the signal power loss is attributed only to the signal propagation from the transmitter node to the receiver node. By contrast, a voltage drop in the receiver batteries causes the RSSI measurement to be detected with higher value. As a result, the estimated distance is now lower than expected.

To compensate for battery effects, we use the reference voltage levels and the real voltage levels to adjust the RSSI measurement to the voltage reference conditions. This loss factor is expressed as

$$\Delta_v = \frac{V_{T0}}{V_T} \cdot \frac{V_R}{V_{R0}}, \quad (18)$$

where  $V_{T0}$  and  $V_{R0}$  are respectively the voltage levels of the transmitter and receiver in the reference conditions, while  $V_T$  and  $V_R$  correspond to actual voltages at the nodes when a RSSI measurement is performed.

## V. EXPERIMENTAL RESULTS

In this section we show the effects of the transducer's angle of incidence and the battery level on RSSI measurement. An incorrect estimate of the RSSI level introduces errors in the distance measurement when the signal propagation model is applied. In subsection V-A, some results about it are shown. This leads to significant localization errors using multilateration. Results for location accuracy achieved with the TELIAMADE system are shown in subsection V-B.

### A. Accuracy in distance measurement

We begin by analyzing the effect of the angle of incidence of the transducers in the RSSI measurement. In Section III, we propose to use the Airy function for modeling the power loss of the transducers with the angle. For this, a pair of nodes placed on a swivel tripod are used. The nodes are placed facing each other at a fixed distance (about 2.0 m) and a certain height above the floor (about 1.6 m). One of them (receiver) is fixed while the other node (transmitter) is rotated at different angles in the range  $[-80^\circ, 80^\circ]$ . The angles are measured using a graduated compass located on the rotation platform of the tripod.

To verify the quality of our approach, we use as reference the losses pattern obtained experimentally with our ultrasonic transducers. Fig. 4 shows the power loss curve for the Airy model (unfilled dots) and the power loss curve from the experimental RSSI measurements using the transducers (filled dots). The similar behavior of both curves indicates that our model is consistent with experimental measurements.

Fig. 5 shows the distance error obtained from RSSI measurements taken at different angles using the ultrasonic signal propagation model. Temperature and relative humidity values are taken for each measurement, being their average values of 21.4 °C and 39 % respectively.

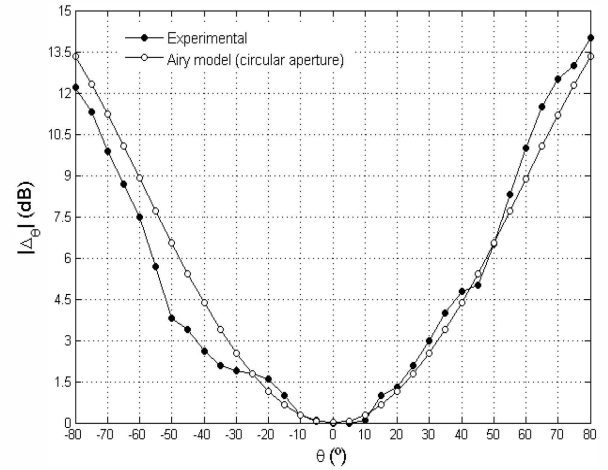

Figure 4. Power-loss due to the orientation of the transducers. The filled dots correspond to power losses experimentally obtained from RSSI measurements using the transducers. By contrast the unfilled dots correspond to the estimated power losses using the loss factor in (17).

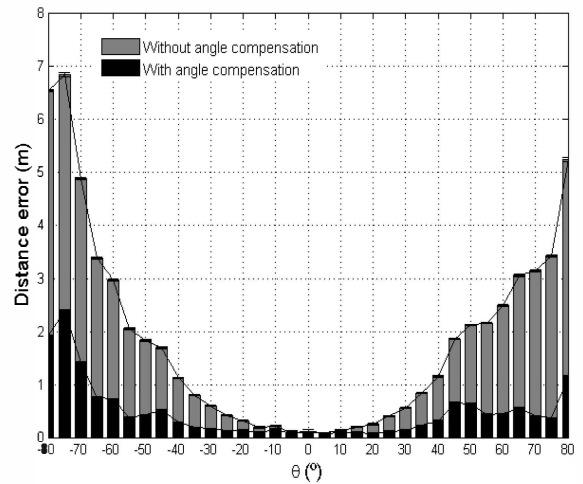

Figure 5. Distance errors obtained using the signal propagation model from RSSI measurements taken at different angles. In grey, distance errors without by-angle loss compensation are shown. In black, the distance errors when loss factor due to angle is used for compensate of the RSSI measurements.

The gray bars show the errors obtained when the compensation of loss power due to angle is not applied. By contrast the black bars show the errors when RSSI measurements are compensated considering the loss factor  $\Delta_\theta$ . An increase of the error when the angular misalignment between transducers grows can be seen. For example for angles exceeding  $\pm 50^\circ$ , errors of several meters are obtained. However, these errors are significantly reduced when the RSSI measurement is compensated with the loss factor  $\Delta_\theta$ . In this case, the errors are less than 0.6 m for angles less than  $\pm 65^\circ$ .

A new experiment was performed to assess the effect of the battery levels on the RSSI measurements. As in the previous experiment, we consider a pair of nodes separated by a fixed distance (about 2.0 m). In this case both transmitter and receiver are aligned so that then the orientation angle between

them is 0°. In this way the RSSI measurements are not affected by losses due to the orientation of the transducers, thus the effect of the battery can be analyzed separately. The nodes are powered by external power supplies instead of their internal batteries (AA batteries) in order to have accurate and adjustable control of the voltage level in the nodes. The nodes are capable of estimating its voltage level ( $V_{in}$ ) in an autonomous way using an adjustable voltage threshold ( $V_{th}$ ) whose resolution is of  $\pm 46.3$  mV. Such inaccuracy can lead to a maximum distance error of 32 mm.

To see the effect of the batteries in the processes of transmission and reception of ultrasonic signal, two tests are carried out. In Test 1, the receiver node is supplied with a fixed voltage of 3.30 V while the transmitter node changes its voltage level in the range [2.65, 3.30] V. Temperature and relative humidity values are taken for each measurement. In this case, their average values are 21.7 °C and 34 % respectively. On the other hand, Test 2 is based on providing a fixed voltage of 3.30 V to the transmitter node, by changing now the voltage of the receiver node in that same range. The average value of temperature for this experiment is of 22.5 °C, with equal relative humidity value. Fig. 6 shows the RSSI measurements obtained for both tests. The filled dots curve shows the RSSI values measured at different voltages when the battery loss compensation is not used (case A). By contrast, the unfilled dots curve shows the compensated RSSI measurements using the loss factor as indicated in (15) (case B). The reference voltage levels ( $V_{T0}, V_{R0}$ ) for the calculation of  $\Delta_V$  are set to 3.30 V. The reference power value  $RSSI_0$  is measured considering the reference voltages. In Fig. 6 the curve of filled dots shows the effect expected in the RSSI measurements when voltage conditions in the nodes is different from the reference voltage conditions. Test 1 lets one see that a voltage drop in the transmitter node reduces the signal power due to a lower gain in transmission. On the other hand, Test 2 shows that a voltage drop in the receiver node increases the received signal power by reducing the dynamic-range of the A/D converter. The compensation algorithm proposed in this work reduces these effects. The curves of unfilled dots represented in Fig. 6 show the effect of this compensation. The nearly flat slope of the compensated curves demonstrates the effectiveness of our adjustment.

To see the effect of such compensation in the final accuracy of the system, the RSSI measurements are converted to distance values. The distance is estimated from the RSSI measurement using an ultrasonic signal propagation model. In Table II are shown the distance errors obtained for the Test 1 and Test 2 considering the cases A and B described above. Data report that a significant improvement in the accuracy of the system is achieved when the RSSI measurements are compensated considering the current batteries level of the nodes with regard to reference voltage conditions. Such compensation allows one to limit the maximum error in the estimation of distance to a value less than 40 mm. It should be mentioned that these error measurements are affected by maximum allowed resolution to estimate the current level of batteries in the nodes (errors of 32 mm may occur because of this imprecision in the estimation of voltage).

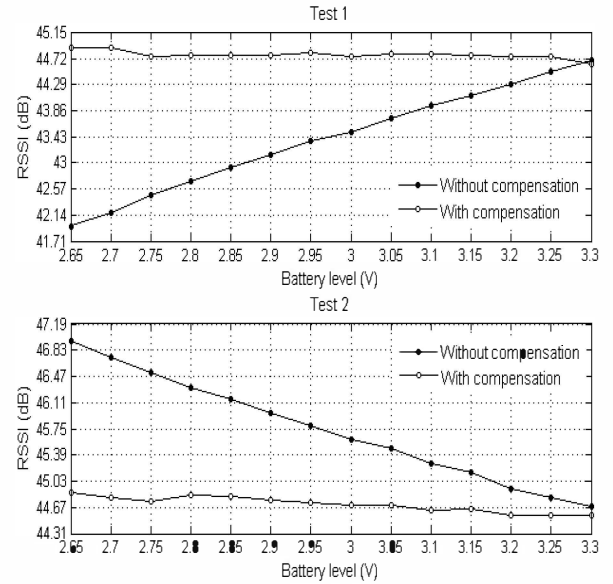

Figure 6. RSSI measurements obtained at different voltage levels. In Test 1, the receiver node is powered with a fixed voltage of 3.30 V by changing the voltage of the transmitter node in the range [2.65, 3.30] V. In Test 2, the transmitter node is powered with a fixed voltage of 3.30 V by changing the voltage of the receiver node in that same range. The curve of filled dots shows the RSSI values measured at different voltages without to use loss compensation due to battery (case A). The curve of unfilled dots shows the RSSI measurements when the battery-loss factor is used (case B).

The significant increase of the error for voltages values below 2.75 V is due to the malfunctioning of some hardware components of the node's design when these are working below this voltage.

TABLE II. ESTIMATED DISTANCE ERRORS BETWEEN TWO NODES SEPARATED BY A FIXED DISTANCE OF 2 M CONSIDERING DIFFERENT VOLTAGE LEVELS. THE DISTANCE IS CALCULATED FROM THE RSSI MEASUREMENT USING AN ULTRASONIC SIGNAL PROPAGATION MODEL. THE RESULTS SHOWN IN TABLE CORRESPOND TO THE EVALUATION OF THE TESTS 1 AND 2 DESCRIBED ABOVE. THE CASE A SHOWS ERRORS WHEN THE COMPENSATION OF BATTERY IS NOT APPLIED WHEREAS THAT CASE B SHOWS ERRORS USING SUCH COMPENSATION.

| Battery (V) | (Test 1)<br>distance error (mm) |        | (Test 2)<br>distance error (mm) |        |
|-------------|---------------------------------|--------|---------------------------------|--------|
|             | Case A                          | Case B | Case A                          | Case B |
| 3.30        | 0.1                             | -9.4   | 0.0                             | -21.5  |
| 3.25        | -32.5                           | 14.8   | 22.6                            | -21.3  |
| 3.20        | -70.9                           | 12.0   | 43.9                            | -22.7  |
| 3.15        | -103.5                          | 15.6   | 82.5                            | -6.0   |
| 3.10        | -137.0                          | 18.9   | 102.3                           | -9.0   |
| 3.05        | -174.4                          | 19.0   | 137.0                           | 3.6    |
| 3.00        | -218.3                          | 14.2   | 157.6                           | 1.3    |
| 2.95        | -247.8                          | 23.5   | 188.3                           | 9.9    |
| 2.90        | -294.1                          | 18.1   | 217.4                           | 16.6   |
| 2.85        | -335.1                          | 18.3   | 247.7                           | 24.3   |
| 2.80        | -381.3                          | 15.1   | 273.5                           | 28.2   |
| 2.75        | -426.6                          | 13.2   | 305.6                           | 11.1   |
| 2.70        | -485.6                          | 39.6   | 338.4                           | 21.6   |
| 2.65        | -532.4                          | 38.4   | 372.0                           | 33.3   |

### B. Indoor positioning accuracy in a real environment

In the previous subsection V-A, the distance measure accuracy is discussed considering the compensation for orientation and consumption of batteries in the RSSI measurement. In this subsection we show the localization accuracy of the TELIAMADE's system by applying multilateration using the estimated distances. Location measurements are performed in an empty room of dimensions (7x5x2.5) m, using four nodes transmitter and a receiver node. The transmitter nodes are placed in the central area of the ceiling, forming a rectangle of dimensions (2.5x2) m, with their ultrasound transducers facing down. This reduces the multipath effects from signals from the surrounding walls. The receiver node is placed in different known coordinate points inside the projected area by transmitter nodes. This node is placed with its transducer ultrasonic facing the ceiling. Fig. 1 helps us understand the deployment of the nodes in this new experiment.

The location accuracy of the system is evaluated at 10 different positions for the receiver node considering several heights. At least 300 RSSI measurements are taken for each transmitter node for each position. The RSSI measurements are compensated taking into account the angle of incidence between the transducers. This angle is estimated by trigonometry using the known coordinates of the transmitter nodes and the receiver node for each position. The effect of the batteries in the RSSI measurement is also compensated using the voltage values estimated by the nodes in each measurement. Finally the RSSI value is converted to distance using signal propagation model described in section II-B. Temperature and relative humidity values are considered at each measurement to achieve a correct estimate of  $\alpha$ . In Table III are shown the average values of the temperature and relative humidity obtained from the set of measurements taken for each position. Fig. 7 shows the 2D-representation of the evaluated test points. The z component is omitted for better visualization of the distribution of the measurements.

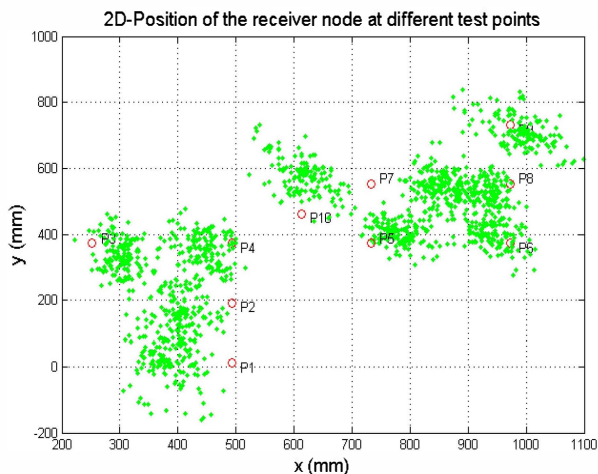

Figure 7. 2D-representation of the evaluated location positions. The unfilled points correspond to the positions where the receiver node is placed (using only coordinates (x,y)). The filled points correspond to the set of localization measurements obtained by applying multilateration from the RSSI measurements.

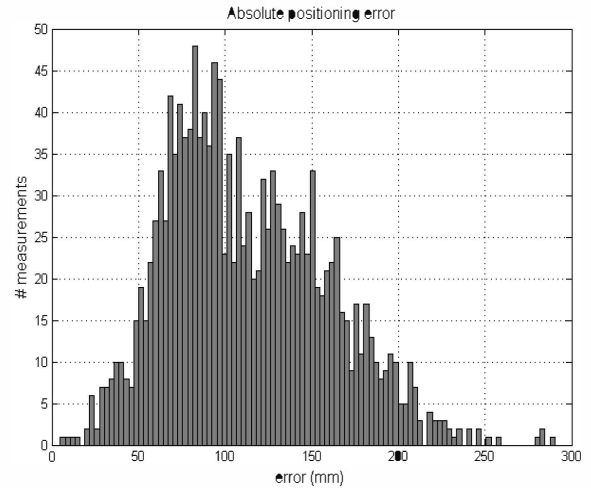

Figure 8. Histogram of the absolute error positioning from the measurements carried out at all positions.

The unfilled points correspond to the positions where the receiver node is placed considering only the coordinates x and y. The filled points correspond to the set of localization measurements obtained by applying multilateration.

The proximity of the experimental-points clouds to the theoretical values demonstrates the effectiveness of the compensation approaches proposed in this work. Fig. 8 shows the histogram of the absolute positioning error considering all measurements carried out. The shape of the error distribution is approximately log-normal with mean 10 cm and a standard deviation of 4.5 cm.

Table III shows the estimated mean error for each component (x, y, z) at the considered test points. Note that errors of less than 10 cm for each component are obtained. The last column of the table shows the root-mean-square error (rmse) obtained from of the measurements taken at each position. A global analysis of the data (considering all error measurements) shows that 95 percent of these errors are less than 19.5 cm. This demonstrates the feasibility of using the RSSI measurement in daily location applications since these errors are perfectly bearable.

TABLE III. AVERAGE VALUE OF THE LOCALIZATION ERROR OBTAINED FOR EACH COMPONENT (X, Y, Z) AND THE ROOT MEAN SQUARE ERROR (RMS) OF THE MEASUREMENTS TAKEN IN THE TEST POINTS. AVERAGE TEMPERATURE AND RELATIVE HUMIDITY VALUES MEASURED FOR EACH POSITION ARE GIVEN..

| Pos. | T (°C) | RH (%) | x-error (mm) | y-error (mm) | z-error (mm) | rmse (mm) |
|------|--------|--------|--------------|--------------|--------------|-----------|
| P1   | 21.6   | 41     | -108.5       | 3.84         | -65.3        | 149.2     |
| P2   | 21.5   | 41     | -87.9        | -18.1        | 4.0          | 112.4     |
| P3   | 23.3   | 32     | 49.7         | -33.0        | -0.8         | 84.3      |
| P4   | 21.6   | 41     | -44.6        | -18.1        | 42.7         | 88.6      |
| P5   | 23.3   | 32     | 49.5         | 36.2         | -44.7        | 92.8      |
| P6   | 21.6   | 41     | -29.3        | 32.1         | 19.9         | 75.8      |
| P7   | 23.2   | 32     | 117.9        | -4.6         | 108.5        | 169.8     |
| P8   | 23.2   | 32     | -50.3        | -21.18       | 61.7         | 100.2     |
| P9   | 21.3   | 42     | 17.3         | -18.7        | 142.6        | 160.9     |
| P10  | 21.3   | 42     | 2.7          | 114.2        | 49.6         | 143.8     |



## VI. CONCLUSIONS

In this paper the performance of an indoor positioning system based on ultrasound RSSI is analyzed. The use of RSSI could potentially mean a simplification of the traditional positioning systems design in relation to other methods such as TOF, being an alternative and interesting method for positioning. The distance between nodes is estimated from RSSI values using a signal propagation model in which the power losses due to the spherical divergence and atmospheric absorption are considered. However, other factors have their impact on RSSI measurements such as the beamwidth of the transducers or the voltage drop of the batteries at the nodes. All this introduces significant errors in the distance estimation and therefore on the positioning accuracy when multilateration is applied.

Herein we propose an approach for modeling the power loss due to the orientation of the ultrasonic transducers, as well as an algorithm to compensate for the effect of the variations in the battery level on RSSI measurements.

To demonstrate the quality of our compensations some experimental results are obtained using a real location system in a controlled environment. The results show a good accuracy of the system with rms location errors lower than 17 cm, in contrast to errors of several meters that typically are obtained for these systems based on RF RSSI measurement [15].

## ACKNOWLEDGMENT

This work was partly supported by the Regional Government of Andalusia under research project P08-ICT-03886. We are pleased with the positive collaboration provided by researchers from the Department of Signal Theory, Networking and Communications at University of Granada and from the Department of Informatics at University of Oslo.

## REFERENCES

- [1] S.Holm and C.Nilsen, "Robust ultrasonic indoor positioning using transmitter arrays," in *Proc. Int. Conf. on Indoor Positioning and Indoor Navigation*, Zurich, September, 2010.
- [2] C.Medina, J.C.Segura and A. I. Torre, "Accurate Time Synchronization of Ultrasonic TOF Measurements in IEEE 802.15.4 based Wireless Sensor Networks," *AD-HOC Networks*, August, 2012., "in press". DOI: 10.1016/j.adhoc.2012.07.005.
- [3] C.Medina, J.C.Segura and A. I. Torre, "A wireless sensor network oriented to localization with sub-centimeter accuracy" – "Una red inalámbrica de sensores orientada a localización con precisión subcentimétrica," in *Proc. 26th Simp. Nacional URSI*, Madrid, Spain, September, 2011. subcentimétrica," in *Proc. 26th Simp. Nacional URSI*, Madrid, Spain, September, 2011.
- [4] Microchip, "28/40/44-Pin Enhanced Flash Microcontrollers with 10-Bit A/D and nanoWatt Technology," [Online]. Available: <http://ww1.microchip.com/downloads/en/DeviceDoc/39626e.pdf>.
- [5] Texas Instruments, "CC2410 2.4 GHz IEEE 802.15.4/ZigBee-ready RF Transceiver," [Online]. Available: <http://www.ti.com/lit/ds/symlink/cc2420.pdf>.
- [6] Prowave, "400ST120/SR120 datasheet," [Online]. Available: <http://www.prowave.com.tw/pdf/T400S12.pdf>.
- [7] Philips Semiconductors, "74HC04, 74HCT04 Hex inverter datasheet," [Online]. Available: [http://www.nxp.com/documents/data\\_sheet/74HC](http://www.nxp.com/documents/data_sheet/74HC).
- [8] National Semiconductor, "LMC6482IN," [Online]. Available: <http://www.ti.com/lit/ds/snos674c/snos674c.pdf>.
- [9] W.Waters and B.R.Harret, "Bandpass signal sampling and coherent detection," *IEEE Trans. on Aerospace and Electronic Systems*, vol.AES-18, no. 4, pp. 731-736, November, 1982.
- [10] J.L.Brown Jr., "On quadrature sampling of bandpass signals," *IEEE Trans. on Aerospace and Electronic Systems*, vol.AES-15, no.3, pp. 366-371, May, 1979.
- [11] S.Holm, "Airborne Ultrasound Data Communications: The Core of an Indoor Positioning System," in *Proc. IEEE Ultrasonics Symposium*, Rotterdam, Netherland, September, 2005.
- [12] H.E.Bass, L.C.Sutherland, A.J.Zuckerwar, D.T.Blackstock and D. Hester, "Atmospheric absorption of sound: Further developments," *Journal of the Acoustical Society of America*, vol. 97, no. 1, pp. 680-683, 1995.
- [13] Sophocles J.Orfanidis, "Electromagnetic Waves and Antennas, Chap.17- Radiation from Apertures," Rutgers University, August, 2010.
- [14] D.Lymeropoulos, Q.Lindsey and A.Savvides, "An Empirical Characterization of Radio Signal Strength Variability in 3-D IEEE 802.15.4 Networks Using Monopole Antennas," *EWSN*, Zurich, Switzerland, February, 2006.
- [15] G. Cherntanomwong y D. Suroso, "Indoor Localization System using Wireless Sensor Networks for Stationary and Moving Target," *Information, Communications and Signal Processing (ICICSP)*, Beijing, China, 2011.