

# EXISTENCE AND UNIQUENESS OF LIMIT CYCLES FOR GENERALIZED $\varphi$ -LAPLACIAN LIÉNARD EQUATIONS

S. PÉREZ-GONZÁLEZ, J. TORREGROSA, AND P. J. TORRES

ABSTRACT. The Liénard equation  $x'' + f(x)x' + g(x) = 0$  appears as a model in many problems of science and engineering. Since the first half of the 20<sup>th</sup> century, many papers have appeared providing existence and uniqueness conditions for limit cycles of Liénard equations. In this paper we extend some of these results for the case of the generalized  $\varphi$ -Laplacian Liénard equation,  $(\varphi(x'))' + f(x)\psi(x') + g(x) = 0$ . This generalization appears when derivations of the equation different from the classical one are considered. In particular, the relativistic van der Pol equation,  $\left(x'/\sqrt{1-(x'/c)^2}\right)' + \mu(x^2 - 1)x' + x = 0$ , has a unique periodic orbit when  $\mu \neq 0$ .

## 1. INTRODUCTION

The Liénard equation,

$$x'' + f(x)x' + g(x) = 0, \quad (1)$$

appears as a model in many areas in science and engineering. It was intensively studied during the first half of the 20<sup>th</sup> century as it can be used to model oscillating circuits or simple pendulums. In the case of the simple pendulum, the functions  $f$  and  $g$  represent the friction and acceleration terms. One of the first models where this equation appeared was introduced by van der Pol [12], considering the equation

$$x'' + \mu(x^2 - 1)x' + x = 0,$$

for modeling the oscillations of a triode vacuum tube. See [7] for other references about more applications.

The first results on existence and uniqueness of periodic solutions of Liénard equations appear in [8, 13]. More references on the existence and uniqueness of limit cycles are [16, 17, 18, 19]. Additionally, [3] and [9] deal with related problems.

In this work, new criteria are presented for existence and uniqueness results of isolated periodic orbits (limit cycles) for the generalized  $\varphi$ -Laplacian Liénard equation

$$(\varphi(x'))' + f(x)\psi(x') + g(x) = 0. \quad (2)$$

Besides the obvious mathematical interest of this generalization, our main motivation for considering this equation comes from relativistic models. Special Relativity imposes a universal bound for the propagation speed of any gravitational or electromagnetic wave. If  $c$  is the speed of light in vacuum, in the framework of Special Relativity the momentum of a particle with unitary rest mass is given by  $\varphi(x') = x'/\sqrt{1-(x'/c)^2}$ , see for instance [6]. The results of the present paper ensure the existence and uniqueness

---

2010 *Mathematics Subject Classification.* Primary 34C25, Secondary: 34K13.

*Key words and phrases.* Existence and Uniqueness; periodic orbits; limit cycles;  $\varphi$ -Laplacian Liénard equations; Generalized Liénard equations.

of a periodic solution for the relativistic van der Pol equation

$$\left( \frac{x'}{\sqrt{1 - (x'/c)^2}} \right)' + \mu(x^2 - 1)x' + x = 0,$$

when  $\mu \neq 0$ . The harmonic relativistic oscillator case,  $\mu = 0$ , is a classical topic studied by several authors, see for instance [5, 11]. Other authors have considered the existence of periodic solutions of damped oscillators with non-autonomous non-linear forces, see [14, 15].

The Liénard equation (1) is commonly expressed as the planar system

$$\begin{cases} \dot{x} = y - F(x), \\ \dot{y} = -g(x), \end{cases} \quad (3)$$

where  $F(x) = \int_0^x f(s)ds$ , or

$$\begin{cases} \dot{x} = y, \\ \dot{y} = -g(x) - f(x)y. \end{cases}$$

Writing equation (2) as the system

$$\begin{cases} \frac{dx}{dt} = y, \\ \varphi'(y) \frac{dy}{dt} = -g(x) - f(x)\psi(y), \end{cases}$$

we can consider the equivalent system

$$\begin{cases} \dot{x} = y\varphi'(y), \\ \dot{y} = -g(x) - f(x)\psi(y), \end{cases} \quad (4)$$

after the time rescaling  $d\tau = dt/\varphi'(y)$ , whenever  $\varphi(y)$  is of class  $\mathcal{C}^{1,1}$  and  $\varphi'(y) \neq 0$  for all  $y$ , where  $\dot{x}, \dot{y}$  denote the derivatives of  $x, y$  with respect to  $\tau$ . In general, system (4) can not be transformed to system (3). Hence the classical results do not apply to the equation proposed in this paper.

Before stating the results, some necessary hypotheses are introduced. All the functions in (2) should be at least locally Lipschitz continuous,  $\mathcal{C}^{0,1}$ , except for  $\varphi(y)$  which should be in  $\mathcal{C}^{1,1}$ . These properties ensure the existence and uniqueness of a solution for any initial value problem associated with system (4). More regularity of each function is required in concrete results. Further regularity conditions of each function are required for [obtaining] more specific results.

Let  $\mathcal{D}$  be a neighborhood of the origin and the largest connected domain for which the four functions in (2),  $\varphi(y)$ ,  $\psi(y)$ ,  $f(x)$  and  $g(x)$ , are well defined. In this way  $\mathcal{D}$  can be considered as  $\mathcal{D} = (x_1, x_2) \times (y_1, y_2)$  where  $x_1, y_1 \in \mathbb{R}^- \cup \{-\infty\}$  and  $x_2, y_2 \in \mathbb{R}^+ \cup \{+\infty\}$ . Throughout this paper all the limits where  $x$  or  $y$  tend to  $x_i$  or  $y_i$  with  $i = 1, 2$  are understood as limits from the interior of the intervals of definition. Hence, for ease of notation, we denote  $y \rightarrow y_2$  instead of  $y \rightarrow y_2^-$ .

Based on the results for the classical Liénard equation (1) given in [16, 17, 19] we state the following hypotheses, denoted by  $(H)$ .

$(H_0)$   $f(x)$ ,  $g(x)$  and  $\psi(y)$  are of class  $\mathcal{C}^{0,1}(\mathbb{R})$  and  $\varphi(y)$  is of class  $\mathcal{C}^{1,1}(\mathbb{R})$ .

$(H_1)$   $xg(x) > 0$  for all  $x \in (x_1, x_2) \setminus \{0\}$  and  $g(0) = 0$ .

$(H_2)$   $f(0) \neq 0$ .

$(H_3)$   $\text{Dom}(\varphi) \subseteq \text{Dom}(\psi)$ .

$(H_4)$   $\psi(0) = 0$ .

$(H_5)$   $\varphi'(y) \in \mathbb{R}^+ \setminus \{0\}$  for all  $y \in (y_1, y_2)$  and  $\varphi(0) = 0$ .

$(H_0)$  represents the regularity condition.  $(H_1)$  and  $(H_2)$  are inherited from the classic results.  $(H_3) - (H_5)$  are the most basic hypotheses that we impose on  $\varphi(y)$  and  $\psi(y)$ . We have included the extra condition  $\varphi(0) = 0$  for simplicity and symmetry reasons. Without loss of generality, the case  $\varphi(0) \neq 0$  can also be considered after doing a translation of this function.

The aim of this work is to provide sufficient conditions on the functions  $f$ ,  $g$ ,  $\varphi$  and  $\psi$  for the existence of a periodic orbit of system (4), and in this case, conditions for uniqueness. The following two theorems summarize these results.

**Theorem 1.** *[Existence Theorem] Consider system (4) under the hypotheses (H) and*

- $(E_0)$   $y\psi(y)f(x) \leq 0$  in a neighborhood of the origin,  $I_x \times I_y = [x_-, x_+] \times [y_-, y_+] \subset \mathcal{D}$ , except for a finite number of points where it vanishes.
- $(E_1)$  There exist  $\delta$  and  $\eta$  in  $\mathbb{R}$ , with  $x_1 < \eta < 0 < \delta < x_2$ , such that  $f(x) > 0$  for all  $x \in (x_1, x_2) \setminus [\eta, \delta]$ .
- $(E_2)$  For each  $i = 1, 2$  there exists  $\lambda_i$  in  $\mathbb{R}^+ \cup \{+\infty\}$  such that, if  $|x_i| = +\infty$ , then  $\liminf_{x \rightarrow x_i} x(|g(x)| + f(x)) = \lambda_i$ , and if  $x_i \in \mathbb{R}$ , then  $\liminf_{x \rightarrow x_i} |x - x_i|(|g(x)| + f(x)) = \lambda_i$ .
- $(E_3)$   $y\psi(y) > 0$  for all  $y \neq 0$ .
- $(E_4)$  In the case that  $y_2 = +\infty$ , if  $\lim_{y \rightarrow +\infty} \varphi(y) = +\infty$ , then  $\liminf_{y \rightarrow +\infty} y^2 \varphi'(y) > 0$ , and if  $\lim_{y \rightarrow +\infty} \varphi(y) = \nu_2 \in \mathbb{R}$ , then  $\liminf_{y \rightarrow +\infty} \varphi'(y)/\varphi'(\nu_2 y/\varphi(0)) > 0$ , and analogously for the case  $y_1 = -\infty$ .

Moreover, one of the following pairs of statements holds  $(E_{5-6})$  or  $(E'_{5-6})$ .

- $(E_5)$  For  $i = 1, 2$ ,  $\lim_{y \rightarrow y_i} \psi(y)/(y\varphi'(y)) \in \mathbb{R}$ .
- $(E_6)$  There exists  $y_0 \in (y_1, y_2)$  such that  $-\psi(y_0) \in \left[ \liminf_{x \rightarrow x_i} g(x)/f(x), \limsup_{x \rightarrow x_i} g(x)/f(x) \right]$  for at least one of the  $x_i$  and there exists  $U$ , neighborhood of  $y_0$ , such that  $\text{sign}(\psi'(y))$  is constant almost for every  $y \in U$ .
- $(E'_5)$  For  $i = 1, 2$ ,  $\lim_{y \rightarrow y_i} \psi(y)/(y\varphi'(y)) = \alpha_i \in \mathbb{R} \setminus \{0\}$ .
- $(E'_6)$  The integral  $\int_\eta^\delta f(x)dx > \frac{4M}{\alpha_i \Lambda_i}(\delta - \eta)$  where  $M = \max_{x \in (\eta, \delta)} |g(x)|$  and  $\Lambda_i = \liminf_{y \rightarrow y_i} y\varphi'(y) > 0$ , for  $i = 1, 2$ .

Then system (4) has at least one periodic orbit contained in  $\mathcal{D}$ .

**Theorem 2.** *[Unicity Theorem] Consider system (4) under the hypotheses (H). Additionally, the following properties hold.*

- $(U_0)$   $f, g \in \mathcal{C}^{0,1}((x_1, x_2))$  and  $\varphi, \psi \in \mathcal{C}^{1,1}((y_1, y_2))$  with  $x_1, y_1 \in \mathbb{R}^- \cup \{-\infty\}$  and  $x_2, y_2 \in \mathbb{R}^+ \cup \{+\infty\}$ .
- $(U_1)$  There exist  $a < 0 < b$  such that  $f(x) < 0$  when  $x \in (a, b)$ , and  $f(x) > 0$  when  $x \in (x_1, x_2) \setminus [a, b]$ .
- $(U_2)$   $g$  satisfies that  $\int_0^a g(s)ds = \int_0^b g(s)ds$ .
- $(U_3)$   $\frac{d}{dx} \left( \frac{f(x)}{g(x)} \right) > 0$ , for all  $x \in (x_1, x_2) \setminus (a, b)$ .
- $(U_4)$   $\psi'(y) > 0$  and  $\frac{d}{dy} \left( \frac{\psi'(y)}{y\varphi'(y)} \right) < 0$ , for all  $y$  in  $(y_1, y_2) \setminus \{0\}$ .

Then system (4) has at most one limit cycle. Moreover, when it exists, it is stable.

Our hypotheses are generalizations of the results in classical references, see [18, 19], and apply, for example, to the van der Pol system. In particular, when  $y\varphi'(y)$  is not

bounded,  $(E'_6)$  forces  $\int_{\eta}^{\delta} f(x)dx$  to be positive (the same hypothesis appears in [17]). Hypotheses  $(U_j)$  are standard in the application of the comparison method for proving uniqueness.

In Section 2, we present different kinds of functions that we have considered in our study. Section 3 is devoted to introducing a new way to bound the domain by mapping  $\mathcal{D}$  to  $\tilde{\mathcal{D}} = (-1, 1) \times (-1, 1)$ . This change allows us to consider the *boundary of  $\mathcal{D}$*  as the inverse of the boundary of  $\tilde{\mathcal{D}}$ . Hence, we can study the behavior of the differential equation (4) close to the boundary of  $\mathcal{D}$ . Moreover, this fact allows us to consider all cases in a unified way. So we restrict our study to the case  $\mathcal{D} = \tilde{\mathcal{D}}$ . In Section 4, we first show integrals of particular cases of (4), i.e. when the friction term  $f(x)$  vanishes,

$$\begin{cases} \dot{x} = y\varphi'(y), \\ \dot{y} = -g(x), \end{cases} \quad (5)$$

or when the acceleration term  $g(x)$  vanishes,

$$\begin{cases} \dot{x} = y\varphi'(y), \\ \dot{y} = -f(x)\psi(y). \end{cases} \quad (6)$$

We use both first integrals as state functions of system (4).

The following sections include all the technical results needed to prove the main results. In Section 5 we prove an existence result, Theorem 1. The proof follows from Poincaré-Bendixson Theorem, see [2], because the statement ensures that the origin and the boundary of  $\mathcal{D}$  have the same stability (they are both repellers). Proposition 6 studies the stability of the origin and Propositions 20 and 21 deal with the stability of the boundary of  $\mathcal{D}$ . Finally, Section 6 is devoted to proving the uniqueness of a limit cycle in the whole space, Theorem 2. The proof, following [19], is obtained by contradiction, computing the integral of the divergence of the vector field between two consecutive limit cycles.

## 2. FAMILIES OF FUNCTIONS

In this paper we consider three different basic behaviors of  $\varphi(y)$  over  $y_i$  for  $i = 1, 2$ . We say that

- (a)  $\varphi(y)$  is *singular* over  $y_i$  if  $y_i \in \mathbb{R}$  and  $\lim_{y \rightarrow y_i} \varphi(y) = \pm\infty$ ,
- (b)  $\varphi(y)$  is *non-bounded regular* over  $y_i$  if  $y_i = \pm\infty$  and  $\lim_{y \rightarrow y_i} \varphi(y) = \pm\infty$ , and,
- (c)  $\varphi(y)$  is *bounded regular* over  $y_i$  if  $y_i = \pm\infty$  and  $\lim_{y \rightarrow y_i} \varphi(y) \in \mathbb{R}^{\pm}$ .

For brevity, we denote the above properties by  $S_i$ ,  $NB_i$  and  $B_i$ , respectively. Graphical representations of these basic functions are shown in Figure 1.

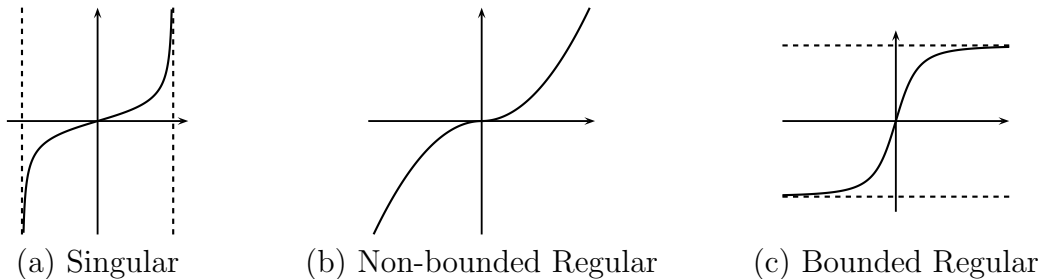

FIGURE 1. Basic  $\varphi$  functions

The most representative function of the singular case could be the relativistic operator,  $\varphi(s) = s/\sqrt{1-s^2}$ . An example of the non-bounded regular case is the p-Laplacian operator,  $\varphi(s) = |s|^{p-1}s$ . And for the bounded regular case, we can use, for example, the mean curvature operator,  $\varphi(s) = s/\sqrt{1+s^2}$ . These three examples are well-known in the literature about  $\varphi$ -Laplacian problems, see for example [1], [10] or [4].

Although the previous examples are all symmetric we do not require any symmetry of the function  $\varphi(y)$ , nor a symmetric behavior at the boundary of the domain. Therefore, mixed cases can also be considered. Hence, the results of this paper also apply to functions like  $\varphi(s) = s/(1-s)$  or  $\varphi(s) = e^s - 1$ , see Figure 2.

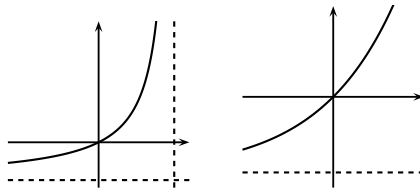

FIGURE 2. Examples of mixed behavior at the boundary of the domain

We also consider different kinds of functions  $f(x)$  in terms of the type of its domain of definition. We say that we are in a *finite (infinite) case on  $x_i$* , denoted by  $F_i (I_i)$ , if  $x_i \in \mathbb{R} (x_i = \pm\infty)$ . The results of this paper also apply when we do not have symmetry in the behavior of  $f(x)$  at both  $x_1$  and  $x_2$  at the same time, as in the case of the function  $\varphi$ . An example of this situation is the function  $f(s) = s^2/(1-s) - 1$ , shown in Figure 3.

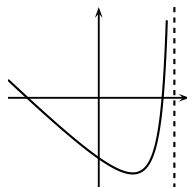

FIGURE 3. A mixed function  $f(x)$

The functions  $g$  and  $\psi$  are actually determined by the hypotheses (H) and, as we show in the following section, they do not play any special role in the compactification. Hence it is not necessary to study their different behaviors at the boundary of the domain.

### 3. BOUNDING THE DOMAIN

The main tool of this work is a transformation of the domain of definition,  $\mathcal{D} = (x_1, x_2) \times (y_1, y_2)$ , of the generalized Liénard differential equation (4). The following proposition allows us to unify all the different behaviors detailed in the previous section via a transformation to the square  $(-1, 1) \times (-1, 1)$ . We consider it as a polygonal compactification because the closure of the new domain is a compact set whose boundary is a polygon. We use the term compactification although it is not really a compactification in the usual sense, because we will extend the flow (4) almost to the whole boundary of the new domain. For example, the flow cannot be extended to the vertices of the square.

**Proposition 3.** *Given system (4) satisfying (H) and defined in  $\mathcal{D} = (x_1, x_2) \times (y_1, y_2)$  where  $x_1, y_1 \in \mathbb{R}^- \cup \{-\infty\}$  and  $x_2, y_2 \in \mathbb{R}^+ \cup \{+\infty\}$ , there exists a change of variables of class  $\mathcal{C}^1$  and, if necessary, a rescaling of time, such that (4) can be written as*

$$\begin{cases} \dot{w} = \chi(z), \\ \dot{z} = -\tilde{g}(w) - \tilde{f}(w)\tilde{\psi}(z). \end{cases} \quad (7)$$

The new domain of definition is  $\tilde{\mathcal{D}} = (-1, 1) \times (-1, 1)$  and the functions  $\tilde{f}$ ,  $\tilde{g}$ ,  $\tilde{\psi}$  and  $\chi$  satisfy the following properties.

- $(\tilde{H}_0)$   $\tilde{f}(w)$ ,  $\tilde{g}(w)$  and  $\tilde{\psi}(z)$ ,  $\chi(z)$  are of class  $\mathcal{C}^{0,1}(\mathbb{R})$ .
- $(\tilde{H}_1)$   $w\tilde{g}(w) > 0$  for all  $w \in (-1, 1) \setminus \{0\}$  and  $\tilde{g}(0) = 0$ .
- $(\tilde{H}_2)$   $\tilde{f}(0) \neq 0$ .
- $(\tilde{H}_3)$   $\text{Dom}(\chi) \subseteq \text{Dom}(\tilde{\psi})$ .
- $(\tilde{H}_4)$   $\tilde{\psi}(0) = 0$ .
- $(\tilde{H}_5)$   $z\chi(z) > 0$  for all  $z \in (-1, 1)$  and  $\chi(0) = 0$ .

From now on we use either system (4) defined in  $\mathcal{D}$  or system (7) defined in  $\tilde{\mathcal{D}}$ . A graphical interpretation of the last result is provided in Figure 4.

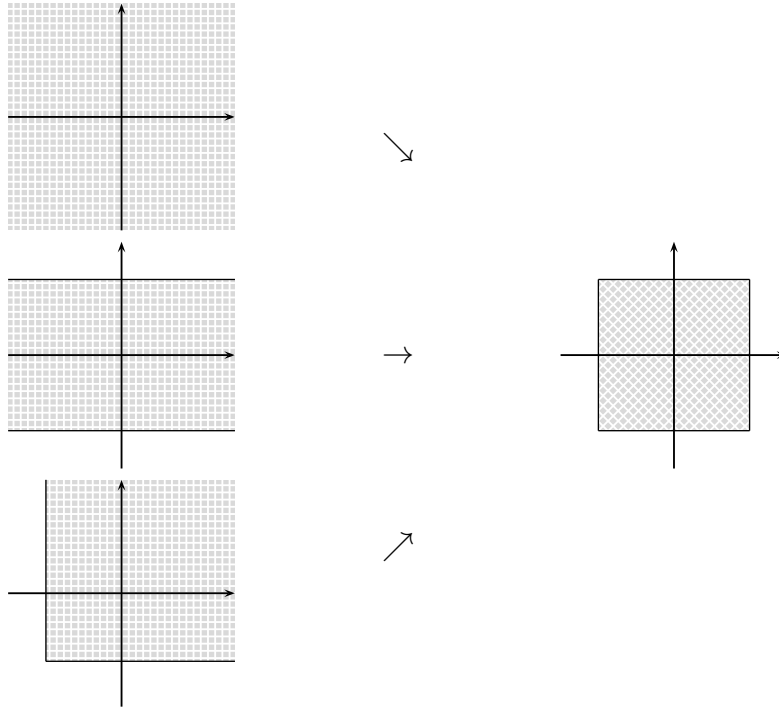

FIGURE 4. Examples of compactified boundaries

*Proof of Proposition 3.* All the functions,  $f$ ,  $g$ ,  $\varphi$  and  $\phi$ , are functions of one variable. Taking into account the symmetry with respect to the origin in the hypotheses (H), we can consider different changes of variables for positive and negative values of the arguments. These changes define a global piecewise change of class  $\mathcal{C}^1$  for the variable  $x$  and another one for the variable  $y$ . Hence system (4) is equivalent to (7) and all the conditions of hypotheses (H) are transformed to the equivalent conditions of hypotheses  $(\tilde{H})$ . From the above considerations we only show the changes corresponding to the first quadrant, that is  $x > 0$  and  $y > 0$ . The remaining quadrants follow analogously.

Using the classification of Section 2 we consider all possible cases  $F_2$ ,  $I_2$ ,  $S_2$ ,  $NB_2$  and  $B_2$  because the changes of variables are different for each type.

For the type  $F_2$ , consider the change of variable

$$w = \frac{x_2 x}{(x_2 - 1)x + x_2}, \text{ whose inverse is } x = c(w)w, \text{ where } c(w) = \frac{x_2}{(1 - x_2)w + x_2},$$

that transforms (4) to

$$\begin{cases} \dot{w} &= y\varphi'(y), \\ \dot{y} &= -\tilde{g}(w) - \tilde{f}(w)\psi(y), \end{cases}$$

after the rescaling of time  $d\sigma/d\tau = 1/c(w)^2$ . Here  $\dot{\cdot}$  denotes the derivative with respect to  $\sigma$ ,

$$\tilde{g}(w) = c(w)^2 g(c(w)w) \quad \text{and} \quad \tilde{f}(w) = c(w)^2 f(c(w)w)$$

and the corresponding side of the boundary of the transformed domain  $\mathcal{D}$  is the line  $w = 1$ .

For the type  $I_2$ , we consider the change of variable

$$w = \frac{x}{1 + |x|} \text{ whose inverse is } x = \frac{w}{1 - |w|}, \quad (8)$$

that transforms (4) to

$$\begin{cases} \dot{w} &= y\varphi'(y), \\ \dot{y} &= -\tilde{g}(w) - \tilde{f}(w)\psi(y), \end{cases}$$

after the rescaling of time  $d\sigma/d\tau = (1 - w)^2$ . Again  $\dot{\cdot}$  denotes the derivative with respect to  $\sigma$ , and we have

$$\tilde{g}(w) = \frac{g\left(\frac{w}{1 - |w|}\right)}{(1 - |w|)^2} \quad \text{and} \quad \tilde{f}(w) = \frac{f\left(\frac{w}{1 - |w|}\right)}{(1 - |w|)^2}.$$

Moreover, the line  $w = 1$  contains the corresponding side of the boundary of the transformed domain  $\mathcal{D}$ .

For the type  $S_2$ , the change of variable

$$z = \frac{y_2^2 y}{y^2 - y_2(2 - y_2)y + y_2^2},$$

whose inverse is

$$y = \frac{y_2}{2z} \left( (2 - y_2)z + y_2 - \sqrt{y_2(z - 1)((y_2 - 4)z - y_2)} \right),$$

changes (4) to

$$\begin{cases} \dot{x} &= \frac{y_2}{2z} \left( (2 - y_2)z + y_2 - \sqrt{y_2(z - 1)((y_2 - 4)z - y_2)} \right) \tilde{\varphi}'(z), \\ \dot{z} &= -g(x) - f(x)\tilde{\psi}(z). \end{cases}$$

Here

$$\begin{aligned} \tilde{\varphi}(z) &= \varphi \left( \frac{y_2}{2z} \left( (2 - y_2)z + y_2 - \sqrt{y_2(z - 1)((y_2 - 4)z - y_2)} \right) \right), \\ \tilde{\psi}(z) &= \psi \left( \frac{y_2}{2z} \left( (2 - y_2)z + y_2 - \sqrt{y_2(z - 1)((y_2 - 4)z - y_2)} \right) \right), \end{aligned}$$

and  $z = 1$  contains the boundary of the transformed domain  $\mathcal{D}$ . We remark that in this case no rescaling of time is needed, so  $\dot{\cdot}$  denotes the derivative with respect to  $\tau$ .

For the type  $NB_2$ , consider the change of variable

$$z = \frac{y}{1 + |y|}, \text{ whose inverse is } y = \frac{z}{1 - |z|}. \quad (9)$$

Then, (4) can be written as

$$\begin{cases} \dot{x} &= z \frac{\tilde{\varphi}'(z)}{1 - |z|}, \\ \dot{z} &= -g(x) - f(x)\tilde{\psi}(z), \end{cases}$$

after the rescaling of time  $d\sigma/d\tau = (1 - |z|)^2$ . Here  $\dot{\cdot}$  denotes the derivative with respect to  $\sigma$ ,

$$\tilde{\varphi}(z) = \varphi\left(\frac{z}{1 - |z|}\right), \quad \tilde{\psi}(z) = \psi\left(\frac{z}{1 - |z|}\right)$$

and  $z = 1$  contains a piece of the boundary of the transformed domain  $\mathcal{D}$ .

Finally, for the type  $B_2$  if  $\lim_{y \rightarrow +\infty} \varphi(y) = \nu_2$ , the change of variable needed is

$$z = \frac{\varphi\left(\frac{\nu_2}{\varphi'(0)}y\right)}{\nu_2}, \text{ whose inverse is } y = \frac{\varphi'(0)}{\nu_2}\varphi^{-1}(\nu_2 z),$$

which allows us to express (4) as follows

$$\begin{cases} \dot{x} &= \gamma(z), \\ \dot{z} &= -g(x) - f(x)\tilde{\psi}(z), \end{cases}$$

after the rescaling of time  $d\sigma/d\tau = \frac{\varphi'(\varphi^{-1}(\nu_2 z))}{\varphi'(0)}$ . As in the previous cases,  $\dot{\cdot}$  denotes the derivative with respect to  $\sigma$ . Here

$$\gamma(z) = \frac{(\varphi'(0))^2}{\nu_2}\varphi^{-1}(\nu_2 z) \frac{\varphi'\left(\frac{\varphi'(0)}{\nu_2}\varphi^{-1}(\nu_2 z)\right)}{\varphi'(\varphi^{-1}(\nu_2 z))}, \quad \tilde{\psi}(z) = \psi\left(\frac{\varphi'(0)}{\nu_2}\varphi^{-1}(\nu_2 z)\right)$$

and again  $z = 1$  contains the boundary of the transformed domain  $\mathcal{D}$ .

The proof ends by checking that the global piecewise changes are all  $\mathcal{C}^1$ . This is done because any of the previous changes are of class  $\mathcal{C}^1$  for  $x \neq 0$  or  $y \neq 0$ . Moreover, the left and right derivatives at the origin coincide, in fact,  $w'(0^+) = w'(0^-) = 1$  and  $z'(0^+) = z'(0^-) = 1$ . Therefore we combine the changes depending on the behavior at  $\mathbb{R}^+$  and  $\mathbb{R}^-$ .  $\square$

Under hypothesis  $(H_0)$ , system (4) satisfies the sufficient conditions to assure existence and uniqueness of any initial value problem in  $\mathcal{D}$ . Then, from the previous proposition, this is also done for the equivalent system (7) in the corresponding domain  $\tilde{\mathcal{D}}$ .

#### 4. STATE FUNCTIONS

In general, a differential equation can be thought of as a dynamical system. A function of state  $E$ , also called state function, is a property of the system that depends only on its current state. That is, the value of the function  $E$  at any point is independent of the system's development before reaching this point. State functions usually appear in physical and chemical systems, for example, the mass, the energy, the entropy or the temperature of a system.



The state functions for system (4) described in this section are constructed as first integrals in the null friction and null acceleration cases, (5) and (6) respectively. They are very helpful in the study of system (4).

**Lemma 4.** *[Primary Energy Function] The function  $E(x, y) = G(x) + \Phi(y)$ , where  $G(x) = \int_0^x g(u)du$  and  $\Phi(y) = \int_0^y v\varphi'(v)dv$ , is a first integral of system (5) in  $\mathcal{D}$ . Moreover  $E(0, 0) = 0$  and the origin is a local center.*

*Proof.* Straightforward computations show that  $E$  is well defined and  $\dot{E} \equiv 0$  over the solutions of system (5). The existence of the first integral and the monodromic structure of the origin imply that the origin is a local center.  $\square$

Likewise, the following result holds.

**Lemma 5.** *[Secondary Energy Function] The function  $J(x, y) = F(x) + \Psi(y)$ , where  $F(x) = \int_0^x f(u)du$  and  $\Psi(y) = \int_0^y \frac{v\varphi'(v)}{\psi(v)}dv$ , is a first integral of system (6) in  $\mathcal{D}$ . Moreover  $J(0, 0) = 0$ .*

## 5. EXISTENCE RESULTS

Theorem 1, our existence result, is a consequence of the results of this section. In order to simplify the exposition we refer to system (4), defined in  $\mathcal{D}$ , for the functions  $f, g, \varphi, \psi$  and to system (7), defined in  $\tilde{\mathcal{D}}$ , for the corresponding transformed functions  $\tilde{f}, \tilde{g}, \tilde{\chi}, \tilde{\psi}$ , via the changes of variables in the proof of Proposition 3. Additionally we also assume hypotheses (H) on (4) and  $(\tilde{H})$  on (7).

**5.1. Local stability of the origin.** Now we show conditions such that system (4) has a singular point at the origin whose stability can be determined.

**Proposition 6.** *Assume that  $f$  and  $\psi$  vanish only on a finite number of points in neighborhoods of the origin  $I_x = [x_-, x_+] \subset (x_1, x_2)$  and  $I_y = [y_-, y_+] \subset (y_1, y_2)$ , respectively. If  $\text{sign } f(x)$  and  $\text{sign } y\psi(y)$  are constant in  $I_x$  and  $I_y$ , then the origin is a repellor (attractor) when  $y\psi(y)f(x) \leq 0$  ( $\geq 0$ ). Moreover the basin of repulsion (attraction) contains the highest level curve of the Primary Energy Function  $E$ , defined in Lemma 4, completely contained in  $I_x \times I_y$ .*

*Proof.* By equation (4) we have

$$\dot{E} = g(x)\dot{x} + y\varphi'(y)\dot{y} = g(x)y\varphi'(y) + y\varphi'(y)(-g(x) - f(x)\psi(y)) = -y\psi(y)\varphi'(y)f(x).$$

As  $\varphi'(y) > 0$  for every  $y \in (y_1, y_2) \setminus \{0\}$  the sign of  $\dot{E}$  is constant in a neighborhood of the origin. Applying Hartman's Theorem, we see that the stability properties of the origin follow from the sign of  $y\psi(y)f(x)$ .  $\square$

**5.2. Stability of infinity.** This section proves that the boundary of  $\mathcal{D}$  is a repellor under the hypotheses of Theorem 1. First, we study how the compactification transforms the hypotheses. Second, Proposition 14 explains the behavior of the orbits close to the boundaries of the compactified domain  $\tilde{\mathcal{D}}$ , and Definition 15 introduces the notion of regular and singular points on the boundary. Propositions 17 and 18 establish the dynamics of the finite points and Corollary 19 shows that their  $\omega$ -limit remains in  $\tilde{\mathcal{D}}$ , or is the entire boundary. Finally, we prove that the boundary is a repellor considering two cases. Proposition 20 deals with the case of singular points on the boundary different from the vertices, and Proposition 21 without such points.

**Lemma 7.** *Assuming  $(E_1)$  then*

$(\tilde{E}_1)$  *there exist  $\tilde{\delta}, \tilde{\eta} \in \mathbb{R}$ , with  $-1 < \tilde{\eta} < 0 < \tilde{\delta} < 1$ , satisfying  $\tilde{f}(w) > 0$  for all  $w \in (-1, 1) \setminus [\tilde{\eta}, \tilde{\delta}]$ .*

**Lemma 8.** *If  $(E_3)$  holds then*

$(\tilde{E}_3)$   $z\tilde{\psi}(z) > 0$ .

**Lemma 9.** *Assume  $(E_6)$ , therefore there exists  $z_0 \in (-1, 1)$  such that  $-\tilde{\psi}(z_0) \in \left[ \liminf_{w \rightarrow w_i} \frac{\tilde{g}(x)}{\tilde{f}(x)}, \limsup_{w \rightarrow w_i} \frac{\tilde{g}(x)}{\tilde{f}(x)} \right]$  for at least one of the  $w_i \in \{-1, 1\}$  and a neighborhood  $\tilde{U}$  of  $z_0$  where  $\text{sign}(\tilde{\psi}'(z))$  is constant for almost every  $z$  in  $\tilde{U}$ .*

The proofs of the above lemmas are straightforward, using the appropriate change of variables from the proof of Proposition 3, and applying the fact that such changes of variables are defined by increasing functions.

**Lemma 10.** *Assume that  $(E_1)$  and  $(E_2)$  hold, then*

$(\tilde{E}_2)$  *there exist  $\tilde{\lambda}_i \in \mathbb{R}^+ \cup \{+\infty\}$  such that  $\liminf_{w \rightarrow w_i} |w - w_i|(|\tilde{g}(w)| + \tilde{f}(w)) = \tilde{\lambda}_i$ , for  $i = 1, 2$ , with  $w_1 = -1$  and  $w_2 = 1$ .*

*Proof.* The statement follows immediately for  $x_i \in \mathbb{R}$ , so we only prove it for  $x_2 = +\infty$ . The case  $x_1 = -\infty$  is analogous. From the change of variables (8) we have

$$\begin{aligned} \liminf_{w \rightarrow 1} |1 - w|(|\tilde{g}(w)| + \tilde{f}(w)) &= \liminf_{x \rightarrow +\infty} \left(1 - \frac{x}{1+x}\right) \frac{g(x) + f(x)}{\left(1 - \frac{x}{1+x}\right)^2} = \\ &= \liminf_{x \rightarrow +\infty} (1 + |x|)(|g(x)| + f(x)) = \beta + \lambda_2. \end{aligned}$$

The above expression is positive because  $\beta = \liminf_{x \rightarrow +\infty} (|g(x)| + f(x)) \geq 0$ , since  $|g(x)|$  and  $f(x)$  are positive functions for  $|x|$  large enough.  $\square$

**Lemma 11.** *Under the hypotheses  $(E_{1-4})$ , function  $\chi$  satisfies*

$(\tilde{E}_4)$   $\lim_{|z| \rightarrow 1} |\chi(z)| = +\infty$ .

*Proof.* Without loss of generality we only consider the case  $z > 0$ . Following the structure of the proof of Proposition 3, we consider the types  $S_2$ ,  $NB_2$  and  $B_2$ .

For  $S_2$  we have  $\chi(z) = \frac{y_2}{2z} ((2 - y_2)z + y_2 - \zeta) \tilde{\varphi}'(z)$  with

$$\tilde{\varphi}'(z) = \frac{((2 - y_2)z + y_2 - \zeta) y_2^2}{2z^2 \zeta} \varphi' \left( \frac{y_2}{2z} ((2 - y_2)z + y_2 - \zeta) \right)$$

and  $\zeta = \sqrt{y_2(z-1)((y_2-4)z - y_2)}$ .

Since we consider the singular type we have  $\lim_{y \rightarrow y_2} \varphi'(y) = +\infty$ . If not,  $\varphi$  can be regularly extended from  $y = y_2$ , which contradicts the maximality of the domain  $\mathcal{D}$ . Thus,

$$\lim_{z \rightarrow 1} \chi(z) = \lim_{y \rightarrow y_2} y \varphi'(y) \frac{(y^2 - y_2(2 - y_2)y + y_2^2)^2}{y_2^2(y_2 - y)(y_2 + y)} = +\infty.$$

For  $NB_2$  we have  $\chi(z) = z\tilde{\varphi}'(z)/(1 - z) = z\varphi'(z/(1 - z))/(1 - z)^3$  with  $z \in (0, 1)$  and

$$\lim_{z \rightarrow 1} \chi(z) = \lim_{y \rightarrow +\infty} y(1 + y)^2 \varphi'(y) = +\infty,$$

because  $\lim_{y \rightarrow +\infty} y^3 \varphi'(y) = +\infty$ . From  $(E_4)$ , there exists  $\alpha > 0$  such that  $\alpha < \liminf_{y \rightarrow +\infty} y^2 \varphi'(y)$ . Then there exists  $y_0 > 0$  such that  $\varphi'(y) > \alpha/y^2$  for all  $y > y_0$ . Hence, it follows that  $y^3 \varphi'(y) > \alpha y$  for all  $y > y_0$ , which concludes the proof.

We finally consider type  $B_2$ . We have

$$\lim_{z \rightarrow 1} \chi(z) = \lim_{z \rightarrow 1} \frac{\varphi'(0)^2}{\nu_2} \varphi^{-1}(\nu_2 z) \frac{\varphi' \left( \frac{\varphi'(0)}{\nu_2} \varphi^{-1}(\nu_2 z) \right)}{\varphi'(\varphi^{-1}(\nu_2 z))} = \lim_{y \rightarrow +\infty} \varphi'(0) y \frac{\varphi'(y)}{\varphi' \left( \frac{\nu_2}{\varphi'(0)} y \right)} = +\infty.$$

As in the unbounded case this follows directly from  $(E_4)$ .  $\square$

**Lemma 12.** *If  $(E_5)$  holds then*

$$(\tilde{E}_5) \quad \lim_{|z| \rightarrow 1} \frac{\tilde{\psi}(z)}{\chi(z)} = 0.$$

*Proof.* We only consider the case  $z \rightarrow 1$ . The case  $z \rightarrow -1$  follows analogously. The different types that should be considered are  $S_2$ ,  $NB_2$  and  $B_2$ .

We start with type  $S_2$ ,

$$\lim_{z \rightarrow 1} \frac{\tilde{\psi}(z)}{\chi(z)} = \lim_{y \rightarrow y_2} \frac{y_2^2 (y_2 - y)(y_2 + y)}{(y^2 - y_2(2 - y_2)y + y_2^2)^2} \frac{\psi(y)}{y \varphi'(y)} = \frac{2}{y_2^3} \lim_{y \rightarrow y_2} (y_2 - y) \frac{\psi(y)}{y \varphi'(y)} = 0.$$

For type  $NB_2$  consider the change (9), and we obtain

$$\lim_{z \rightarrow 1} \frac{\tilde{\psi}(z)}{\chi(z)} = \lim_{z \rightarrow 1} (1 - z) \frac{\psi \left( \frac{z}{1 - z} \right)}{\frac{z}{1 - z} \varphi' \left( \frac{z}{1 - z} \right)} = \lim_{y \rightarrow +\infty} \frac{1}{1 + y} \frac{\psi(y)}{y \varphi'(y)} = 0.$$

Finally, consider type  $B_2$ . Since  $\lim_{y \rightarrow +\infty} \varphi'(y) = 0$ , we have

$$\lim_{z \rightarrow 1} \frac{\tilde{\psi}(z)}{\chi(z)} = \lim_{y \rightarrow +\infty} \frac{\psi(y) \varphi' \left( \frac{\nu_2}{\varphi'(0)} y \right)}{\varphi'(0) y \varphi'(y)} = \frac{1}{\varphi'(0)} \lim_{y \rightarrow +\infty} \frac{\psi(y)}{y \varphi'(y)} \varphi' \left( \frac{\nu_2}{\varphi'(0)} y \right) = 0. \quad \square$$

**Lemma 13.** *Let  $h$  be a function of class  $C^{0,1}([0, 1])$ . If  $\liminf_{s \rightarrow 1} (1 - s)h(s) > 0$ , then  $\int_0^1 h(s) ds = +\infty$ .*

*Proof.* By assumption,  $\liminf_{s \rightarrow 1} (1 - s)h(s) = \lambda$ , for a positive real number  $\lambda$ . Thus, there exists  $\varepsilon \in (0, 1)$  such that  $h(s) \geq \lambda/(2(1 - s))$ , for all  $s \in (1 - \varepsilon, 1)$ . Hence,

$$\int_0^1 h(s) ds = \int_0^{1-\varepsilon} h(s) ds + \int_{1-\varepsilon}^1 h(s) ds.$$

The proof is complete because  $h(s)$  is bounded in  $[0, 1 - \varepsilon]$  and

$$\int_{1-\varepsilon}^1 h(s) ds \geq \int_{1-\varepsilon}^1 \frac{\lambda}{2} \frac{1}{1 - s} ds = +\infty. \quad \square$$

The following result extends the dynamics to the boundary of  $\tilde{D}$ . Subsequently, we study the behavior of the orbits in each quadrant.

**Proposition 14.** *Consider system (7) under the hypotheses  $(\tilde{H})$ . Additionally we assume that*

- $(\tilde{E}_1)$  *there exist real numbers  $\tilde{\delta}, \tilde{\eta}$ , such that  $-1 < \tilde{\eta} < 0 < \tilde{\delta} < 1$ , and  $\tilde{f}(w) > 0$  for all  $w \in (-1, 1) \setminus [\tilde{\eta}, \tilde{\delta}]$ ,*
- $(\tilde{E}_2)$  *there exists  $\tilde{\lambda}_i \in \mathbb{R}^+ \cup \{+\infty\}$  with  $\liminf_{w \rightarrow w_i} |w - w_i|(|\tilde{g}(w)| + \tilde{f}(w)) = \tilde{\lambda}_i$ , for  $i = 1, 2$  with  $w_1 = -1$  and  $w_2 = 1$ ,*
- $(\tilde{E}_3)$   *$z\tilde{\psi}(z) > 0$  for all  $z \neq 0$ ,*
- $(\tilde{E}_4)$   *$\lim_{|z| \rightarrow 1} \tilde{\psi}(z)/\chi(z) = 0$ , for  $i = 1, 2$ , and*
- $(\tilde{E}_5)$   *$\lim_{|z| \rightarrow 1} |\chi(z)| = +\infty$ .*

Then for  $i = 1, 2$ , given  $w_0, z_0 \in (-1, 1)$  such that  $-\tilde{\psi}(z_0) \notin \left[ \liminf_{w \rightarrow w_i} \frac{\tilde{g}(w)}{\tilde{f}(w)}, \limsup_{w \rightarrow w_i} \frac{\tilde{g}(w)}{\tilde{f}(w)} \right]$ , the vector field defined by (7) is topologically equivalent to

$$\begin{cases} \dot{w} = \text{sign}(\pm 1), \\ \dot{z} = 0, \end{cases} \quad \text{or} \quad \begin{cases} \dot{w} = 0, \\ \dot{z} = \lim_{w \rightarrow w_i} \text{sign}(-\tilde{g}(w) - \tilde{f}(w)\tilde{\psi}(z_0)), \end{cases}$$

in a neighborhood of  $(w_0, \pm 1)$  or  $(\pm 1, z_0)$ , respectively.

*Proof.* First we prove the equivalence for neighborhoods of points  $(w_0, \pm 1)$ . For any  $z \neq 0$ , we can rewrite system (7) with a positive time rescaling as

$$\begin{cases} \dot{w} = \text{sign}(\chi(z)), \\ \dot{z} = \frac{-\tilde{g}(w) - \tilde{f}(w)\tilde{\psi}(z)}{|\chi(z)|}. \end{cases} \quad (10)$$

For any fixed  $w_0 \in (-1, 1)$ , applying  $(\tilde{E}_4)$  and  $(\tilde{E}_5)$ , we have  $\dot{z} \rightarrow 0$  when  $z \rightarrow \pm 1$ . This means that the segments of the boundary of  $\tilde{\mathcal{D}}$  contained in  $\{z = \pm 1\}$  are invariant for (10). Using hypotheses  $(\tilde{H})$ ,  $\chi(z)$  and  $z$  have the same sign, which completes the proof for this case.

Finally, we prove the equivalence for neighborhoods of points  $(1, z_0)$ . For the points  $(-1, z_0)$  the proof is analogous. For any  $z_0$  satisfying  $-\tilde{\psi}(z_0) \notin \left[ \liminf_{w \rightarrow 1} \tilde{g}(w)/\tilde{f}(w), \limsup_{w \rightarrow 1} \tilde{g}(w)/\tilde{f}(w) \right]$  there exists a neighborhood of  $(1, z_0)$  in  $\tilde{\mathcal{D}}$  such that  $\tilde{g}(w) + \tilde{f}(w)\tilde{\psi}(z)$  does not vanish. In this neighborhood, system (7) is equivalent to

$$\begin{cases} \dot{w} = \frac{\chi(z)}{|-\tilde{g}(w) - \tilde{f}(w)\tilde{\psi}(z)|}, \\ \dot{z} = \text{sign}(-\tilde{g}(w) - \tilde{f}(w)\tilde{\psi}(z)). \end{cases}$$

Hence, the equivalence follows similarly to the previous case.  $\square$

**Definition 15.** *We say that the points  $(w_0, \pm 1)$  or  $(\pm 1, z_0)$ , are regular points in the boundary when they satisfy the properties of Proposition 14. The other points, including the vertex, are called singular.*

**Remark 16.** *Proposition 14 extends the dynamical behavior of system (7) in  $\tilde{\mathcal{D}}$  to the regular points of its closure. See a possible phase portrait in Figure 5.*

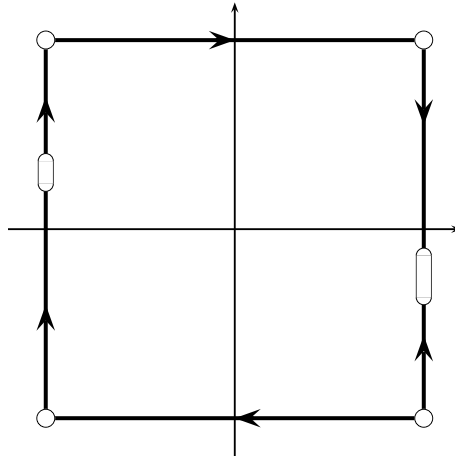

FIGURE 5. An example of a phase portrait on the boundary. The rounded regions represent the set of singular points

**Proposition 17.** *Under the assumptions of Proposition 14, the positive orbit of every point in  $[0, 1) \times (0, 1)$  (resp. in  $(-1, 0] \times (-1, 0)$ ) cuts the segment  $(0, 1) \times \{0\}$  (resp.  $(-1, 0) \times \{0\}$ ) transversally in finite time. See Figure 6.*

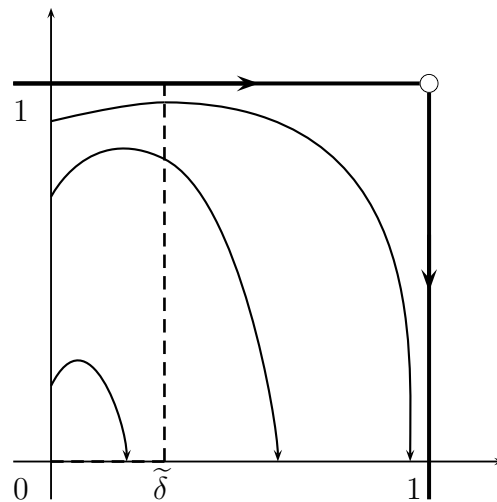

FIGURE 6. Phase portrait of system (7) for the first quadrant

*Proof.* We only prove the result for the first quadrant. For the remaining quadrants the proofs follow by symmetry.

The first component of the vector field in the points over the positive  $z$ -axis is greater than zero. Proposition 14 provides a Flow Box argument for the vector field (7) in the neighborhood of the points  $(0, 1) \times \{1\}$ . As there are no critical points with  $w > 0$ ,  $z > 0$  in  $\tilde{\mathcal{D}}$ , the proof follows from the Poincaré-Bendixson Theorem, once we show that there are no orbits tending to  $(1, z_0)$  with  $z_0 > 0$ . We prove this by contradiction.

In a neighborhood of the segment  $\{1\} \times (0, 1)$  in  $\tilde{\mathcal{D}}$ , condition  $(\tilde{E}_2)$  implies that  $\lim_{w \rightarrow 1} (1-w)\tilde{g}(w)$  or  $\lim_{w \rightarrow 1} (1-w)\tilde{f}(w)$  is strictly positive. Then, after the changes of variables of Proposition 3, one of the state functions of Section 4,

$$\begin{aligned}\tilde{E}(w, z) &= \tilde{G}(w) + \tilde{\Phi}(z) = \int_0^w \tilde{g}(u) du + \int_0^z \chi(v) dv \quad \text{and} \\ \tilde{J}(w, z) &= \tilde{F}(w) + \tilde{\Psi}(z) = \int_0^w \tilde{f}(u) du + \int_0^z \frac{\chi(v)}{\tilde{\psi}(v)} dv,\end{aligned}$$

goes to infinity when  $(w, z)$  tends to the boundary of  $\tilde{\mathcal{D}}$  by Lemma 13.

Therefore, if an orbit approaches the boundary, one of the state functions goes to infinity. This contradicts the fact that both state functions decrease over the solutions of the vector field on the region  $w > \tilde{\delta}$  and  $z > 0$ . Note that by (i) and  $(\tilde{H})$ ,

$$\dot{\tilde{E}}(w, z) = \tilde{g}(w)\dot{w} + \chi(z)\dot{z} = -\tilde{f}(w)\tilde{\psi}(z)\chi(z) < 0,$$

and

$$\dot{\tilde{J}}(w, z) = \tilde{f}(w)\dot{w} + \frac{\chi(z)}{\tilde{\psi}(z)}\dot{z} = -\tilde{g}(w)\frac{\chi(z)}{\tilde{\psi}(z)} < 0.$$

□

**Proposition 18.** *Under the assumptions of Proposition 14, the positive orbit of every point in  $(0, 1) \times (-1, 0]$  (resp. in  $(-1, 0) \times [0, 1)$ ) cuts the segment  $\{0\} \times (-1, 0)$  (resp.  $\{0\} \times (0, 1)$ ) transversally in finite time. See Figure 7.*

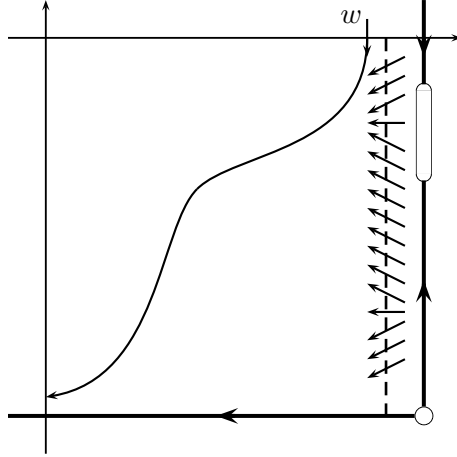

FIGURE 7. Phase portrait of system (7) on the fourth quadrant

*Proof.* We only prove the result for the fourth quadrant. For proof for the others follow by symmetry.

The second component of the vector field on the points over the positive  $w$ -axis is negative. Proposition 14 provides a Flow Box argument for the vector field (7) in the neighborhood of the points  $(0, 1) \times \{-1\}$ . As there are no critical points with  $w > 0$ ,  $z < 0$  in  $\tilde{\mathcal{D}}$ , the proof follows from the Poincaré-Bendixson Theorem, using the condition  $\dot{w} = \chi(z) < 0$  on the fourth quadrant. □

The last two propositions imply the following corollary.

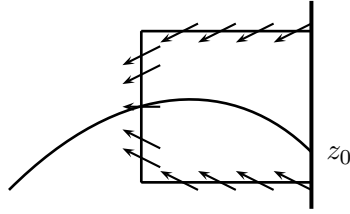

FIGURE 8. Behavior of the flux near to an isolated singular point in the boundary

**Corollary 19.** *The  $\omega$ -limit of each point in  $\tilde{\mathcal{D}}$  is contained in  $\tilde{\mathcal{D}}$  or it is the whole boundary of  $\tilde{\mathcal{D}}$ .*

Finally, the proof of Theorem 1 follows from the following two propositions. In the first result, the boundary always presents singular points besides the vertices, while in the second it does not.

**Proposition 20.** *Consider system (4) under the hypotheses (H), satisfying  $(E_{1-6})$  from Theorem 1. Then, the boundary of  $\mathcal{D}$  is a repellor.*

*Proof.* Applying Lemmas 8 to 12 to system (7), we can compactify, and the resulting system satisfies the hypotheses of Proposition 14. Then, from statement  $(E_6)$  (see Lemma 9), there exists  $z_0 \in (-1, 1)$  such that  $-\tilde{\psi}(z_0)$  is in  $I_i = \left[ \liminf_{w \rightarrow w_i} \tilde{g}(w)/\tilde{f}(w), \limsup_{w \rightarrow w_i} \tilde{g}(w)/\tilde{f}(w) \right]$  for at least one of the  $w_i \in \{-1, 1\}$ , and there exists a neighborhood,  $\tilde{U}$ , of  $z_0$  such that  $\text{sign}(\tilde{\psi}'(z))$  is constant for almost every  $z \in \tilde{U}$ .

Without loss of generality we only prove the case  $w_2 = 1$  and  $\tilde{\psi}'(z) > 0$ .

The proof is done in two steps. We first study the behavior of the vector field close to  $(1, z_0)$  and secondly, we construct a negatively invariant region that proves that infinity is a repellor. For the first step we distinguish two cases:  $I_2$  just contains an isolated point, or it is a proper interval. The behavior of the vector field in both cases is similar. Thus, we present the first case, and then only explain the differences between the two cases.

In the first case, we have an isolated  $z_0 \in (-1, 0)$  such that  $-\tilde{\psi}(z_0) = \lim_{w \rightarrow 1} \tilde{g}(w)/\tilde{f}(w)$ . Consider a rectangular domain  $\tilde{\mathcal{R}} = (\Omega, 1) \times (\zeta_1, \zeta_2)$  such that  $z_0 \in (\zeta_1, \zeta_2) \subset \tilde{U}$  and  $(\Omega, 1) \times \{\zeta_i\} \cap \{(z, w) \in (-1, 1) \times (-1, 1) : -\tilde{\psi}(z) = \tilde{g}(w)/\tilde{f}(w)\} = \emptyset$  for  $i = 1, 2$ . See Figure 8. If we assume that  $\tilde{\psi}'(z) > 0$  almost everywhere in  $\tilde{U}$ , the vector field at the top and bottom boundaries of  $\tilde{\mathcal{R}}$  points to the interior of  $\tilde{\mathcal{R}}$ . In the other case the vector field points to the exterior of  $\tilde{\mathcal{R}}$ . In both cases, the vector field at  $\{\Omega\} \times (\zeta_1, \zeta_2)$  points to the exterior of  $\tilde{\mathcal{R}}$ . Figure 8 shows the case  $\tilde{\psi}'(z) > 0$ .

Due to this behavior on the boundary and using the existence and uniqueness of solutions for each point in  $\tilde{\mathcal{R}}$ , we conclude that there exists a separatrix,  $\Gamma(z)$ , between the orbits that cut the top boundary and the orbits that cut the bottom. This  $\Gamma(z)$  is an orbit of the vector field in  $\tilde{\mathcal{R}}$  whose  $\alpha$ -limit set is  $\{z_0\}$ , the unique singular point in the closure of  $\tilde{\mathcal{R}}$ . From now on, we denote this orbit as  $\Gamma(z_0)$ .

In the second case,  $I_2$  is a proper interval,  $z_0$  can be not isolated and it can be contained in a subinterval  $\tilde{I}_2 \subset (-1, 0)$  such that for any  $z$  in  $\tilde{I}_2$  we have that  $-\tilde{\psi}(z)$  is in  $I_2$ . In this case,  $\tilde{U}$  can be considered as before but containing  $\tilde{I}_2$ .  $\tilde{\mathcal{R}}$  is constructed in

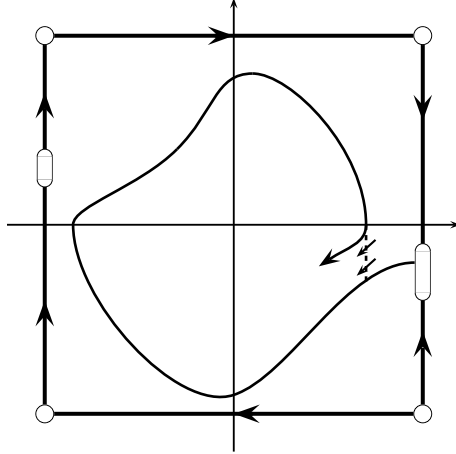

FIGURE 9. Positively invariant region when the boundary has singular points different from the vertex.

the same way as the previous case, but now  $z_0 \in \tilde{I}_2 \subset (\zeta_1, \zeta_2) \subset \tilde{U}$ . Then, arguing as in the previous case, there exists an orbit,  $\Gamma(z_0)$ , such that  $z_0$  is in the  $\alpha$ -limit set of  $\Gamma(z_0)$ .

For the second step, Propositions 17 and 18 imply that the orbit  $\Gamma(z_0)$  touches the positive  $w$ -axis in finite time, passing through all quadrants in clockwise direction. We call  $(\hat{w}, 0)$  the first time that this occurs and  $(\hat{w}, \hat{z})$  the first time that the orbit  $\Gamma(z_0)$  cuts the straight line  $w = \hat{w}$  in the fourth quadrant. Then, by  $(\tilde{H}_5)$ , the region defined by  $\Gamma(z_0)$  between  $(\hat{w}, \hat{z})$  and  $(\hat{w}, 0)$  and the segment with those endpoints,  $\hat{S}$ , is positively invariant. This completes the proof because the positive orbits of all points in the complement of this region in  $\tilde{D}$  cross the segment  $\hat{S}$ , see Figure 9.  $\square$

**Proposition 21.** *Consider system (4) under the hypotheses (H), satisfying  $(E_{1-4})$  and  $(E'_{5-6})$  from Theorem 1. Then the boundary of  $\mathcal{D}$  is a repellor.*

*Proof.* We show in two steps that the boundary of  $\mathcal{D}$  is a repellor. Firstly, we ensure the existence of a return map over a transversal segment close to the boundary in the compactified space  $\tilde{\mathcal{D}}$ . Secondly, we analyze the energy  $E$  given in Lemma 4 along the orbits in  $\mathcal{D}$ , which were obtained by the inverse of the compactification of the orbits starting in the greater points of this segment in  $\tilde{\mathcal{D}}$ .

After the compactification proposed in Proposition 3, the continuity argument of Proposition 14 and the fact that no orbit inside  $\tilde{\mathcal{D}}$  intersects its boundary, given by Propositions 17 and 18, ensure the existence of a first return map close to the boundary. Moreover, for  $\varepsilon > 0$  small enough, there exists  $0 < \varepsilon_0 \ll \varepsilon$  such that for any  $\zeta_0 \in (1 - \varepsilon_0, 1)$  the orbit,  $\Gamma_{\zeta_0}$ , that starts at  $(\tilde{\eta}, \zeta_0)$  cuts after a time  $T$ , the first return time, the segment  $\{\tilde{\eta}\} \times (1 - \varepsilon, 1)$  at  $(\tilde{\eta}, \zeta_T)$  and remains in  $(-1, 1) \times (-1, 1) \setminus (-1 + \varepsilon, 1 - \varepsilon) \times (-1 + \varepsilon, 1 - \varepsilon)$  for the time interval  $[0, T]$ . See Figure 10. We denote by  $(\tilde{\eta}, \zeta_0)$ ,  $(\tilde{\delta}, \zeta_1)$ ,  $(\tilde{\delta}, \zeta_2)$ ,  $(\tilde{\eta}, \zeta_3)$  and  $(\tilde{\eta}, \zeta_T)$  the consecutive cutting points of  $\Gamma_{\zeta_0}$  with the segments  $\{\tilde{\eta}\} \times (-1, 1)$  and  $\{\tilde{\delta}\} \times (-1, 1)$ . Consequently,  $\zeta_0, \zeta_1, \zeta_T \in (1 - \varepsilon, 1)$  and  $\zeta_2, \zeta_3 \in (-1, -1 + \varepsilon)$ .

For any  $\zeta_0 \in (1 - \varepsilon_0, 1)$ , the transformation of its orbit in  $\tilde{\mathcal{D}}$  by the inverse of the compactification in Proposition 3 is an orbit in  $\mathcal{D}$  that passes through  $(\eta, \rho_i)$  and  $(\delta, \rho_j)$ , the points corresponding to  $(\tilde{\eta}, \zeta_i)$  and  $(\tilde{\delta}, \zeta_j)$  previously introduced. So, the statement

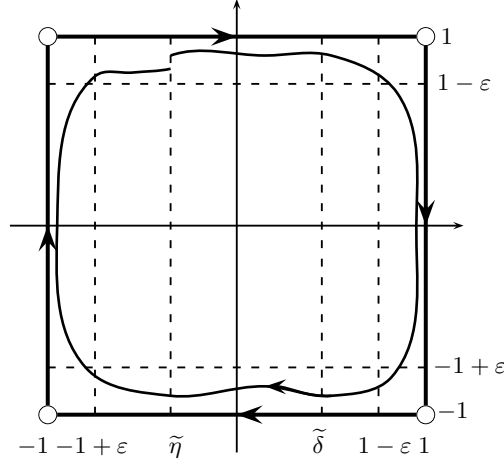

FIGURE 10. Phase portrait of  $\Gamma_{\zeta_0}$ 

will follow if we can show that the value of the primary energy function  $E$  in  $(\eta, \rho_T)$  is lower than in  $(\eta, \rho_0)$ . Since  $y \frac{\partial E}{\partial y} = y^2 \varphi'(y) > 0$  for all  $y \neq 0$  and, consequently,  $E$  grows when  $|y|$  grows. So if we prove that  $E$  decreases after the first return we have that  $\rho_T \leq \rho_0$ . In fact, what we will prove is that  $E$  decreases when the orbit passes through consecutive cutting points,  $(\eta, \rho_i)$  and  $(\delta, \rho_j)$ .

From  $(E'_5)$  and  $(E'_6)$  and considering orbits sufficiently close to the boundary, equivalently considering the previous transformed orbits for  $\varepsilon$  small enough, there exists a positive real number  $A \lesssim \Lambda_2$  such that for any point,  $(x, y)$ , of the orbit connecting  $(\eta, \rho_0)$  and  $(\delta, \rho_1)$  we have  $y \varphi'(y) > A$  and  $-\int_{\eta}^{\delta} f(s) ds + 4M(\delta - \eta)/(\alpha_2 A) < 0$ . Moreover, there exists a positive real number  $\kappa$  such that along the same segment of the orbit we have  $\alpha - \kappa < \psi(y)/y \varphi'(y) < \alpha + \kappa$  and  $\frac{\alpha_2}{2} \int_{\eta}^{\delta} f(x) dx > \kappa \int_{\eta}^{\delta} |f(x)| dx$ . So, integrating along the orbit, we have that

$$\begin{aligned} \int_{\eta}^{\delta} \frac{f(x) \psi(y)}{y \varphi'(y)} dx &\geq \int_{\eta}^{\delta} f^+(x) (\alpha_2 - \kappa) dx - \int_{\eta}^{\delta} f^-(x) (\alpha_2 + \kappa) dx \\ &= \alpha_2 \int_{\eta}^{\delta} (f^+(x) - f^-(x)) dx - \kappa \int_{\eta}^{\delta} (f^+(x) + f^-(x)) dx \\ &= \alpha_2 \int_{\eta}^{\delta} f(x) dx - \kappa \int_{\eta}^{\delta} |f(x)| dx > \frac{\alpha_2}{2} \int_{\eta}^{\delta} f(x) dx. \end{aligned}$$

Hence, writing equation (4) as  $dy/dx = -g(x)/(y \varphi'(y)) - f(x) \psi(y)/(y \varphi'(y))$ , we can estimate the differences

$$\begin{aligned} \rho_1 - \rho_0 &= \int_{\eta}^{\delta} \left( -\frac{g(x)}{y \varphi'(y)} - \frac{f(x) \psi(y)}{y \varphi'(y)} \right) dx \leq \frac{M}{A} (\delta - \eta) - \frac{\alpha_2}{2} \int_{\eta}^{\delta} f(x) dx, \\ G(\delta) - G(\eta) &= \int_{\eta}^{\delta} g(x) dx \leq M(\delta - \eta), \\ \Phi(\rho_1) - \Phi(\rho_0) &= -\int_{\rho_1}^{\rho_0} y \varphi'(y) dy \leq -A(\rho_0 - \rho_1). \end{aligned}$$

Here  $G$  and  $\Phi$  are the functions defined in Lemma 4. Thus, the primary energy function satisfies

$$E(\delta, \rho_1) - E(\eta, \rho_0) \leq M(\delta - \eta) + A(\rho_1 - \rho_0) \leq 2M(\delta - \eta) - A\frac{\alpha_2}{2} \int_{\eta}^{\delta} f(x)dx < 0.$$

So, the energy decreases from  $(\eta, \rho_0)$  to  $(\delta, \rho_1)$  and from  $(\delta, \rho_2)$  to  $(\eta, \rho_3)$ , applying the same argument replacing  $\rho_0$  and  $\rho_1$  by  $\rho_2$  and  $\rho_3$ , respectively.

Finally, the energy also decreases from  $(\delta, \rho_1)$  to  $(\delta, \rho_2)$  and from  $(\eta, \rho_3)$  to  $(\eta, \rho_T)$  because  $f(x) > 0$  and  $\dot{E} = -f(x)y\varphi'(y)\psi(y) \leq 0$ , for all  $x \in (x_1, x_2) \setminus [\eta, \delta]$  and  $y \in (y_1, y_2)$ .  $\square$

## 6. UNIQUENESS OF THE LIMIT CYCLE

This section is devoted to proving the uniqueness result, Theorem 2, by contradiction. The proof follows the steps of the proofs of Theorems 4.6 and 4.7 in Chapter IV in [19]. Firstly, we see that all the periodic orbits contain in its interior the segment  $(a, b) \times \{0\}$ . Secondly, we study the stability of two limit cycles  $\Gamma_1$  and  $\Gamma_2$  as depicted in Figure 11. In fact, we will prove that  $\Gamma_2$  is stable and  $\Gamma_1$  is stable or semistable. Finally we will see that there are no semistable limit cycles. This proves that there is at most one limit cycle. If it exists it is stable because, as we have seen in Section 5, the origin and the boundary are repellers in this case.

Firstly, notice that Proposition 6 shows that the origin is the unique singular point, which is a repellor. Additionally, there is no periodic orbit entirely contained in  $(a, b) \times (y_1, y_2)$  because  $\dot{E} = -f(x)y\varphi'(y)\psi(y) > 0$ , for all  $(x, y) \in (a, b) \times (y_1, y_2) \setminus \{(0, 0)\}$ . Moreover, all the periodic orbits contain the region  $\{(x, y) \in \mathcal{D} : 0 \leq E(x, y) \leq G(a) = G(b)\}$ , because it is negatively invariant. So, all the periodic orbits contain the segment  $(a, b) \times \{0\}$ .

We will denote by  $\Gamma_1$  the limit cycle closest to the origin. As the origin is a repellor,  $\Gamma_1$  cannot be unstable, hence it is stable or semistable. Therefore,  $\int_{\Gamma_1} \text{div } X dt \leq 0$ . We recall that the stability of a periodic orbit can be determined from the integral of the divergence of a vector field along the orbit, see Section 2 in Chapter IV in [19].

The proof of the second step is done by a comparison method. Suppose that we have a second limit cycle  $\Gamma_2$  with different stability of  $\Gamma_1$  and with no other periodic trajectories between them, see Figure 11. Then we prove that the difference between the integral of the divergence of the vector field (4) along both orbits is different from zero, in fact it is negative, or equivalently  $\int_{\Gamma_2} \text{div } X dt < \int_{\Gamma_1} \text{div } X dt \leq 0$ . But this contradicts the existence of this second limit cycle, since it implies that both limit cycles have the same stability.

Now we compute the integral of the divergence of equation (4),

$$\text{div } X = \frac{d}{dx}(y\varphi'(y)) + \frac{d}{dy}(-g(x) - f(x)\psi(y)) = -f(x)\psi'(y),$$

between both periodic orbits by using Green's Lemma. The integral of the divergence along the set  $\Gamma_2 - \Gamma_1$  can be written as

$$\int_{\Gamma_2 - \Gamma_1} \text{div } X dt = \iint_{\mathcal{G}} \omega dx dy, \quad (11)$$

where  $\mathcal{G}$  is the region enclosed by  $\Gamma_1$  and  $\Gamma_2$ , see also Figure 11, and  $\omega$  depends on  $X$  and the parametrization of  $t$ . However,  $t$  cannot be easily reparametrized all around

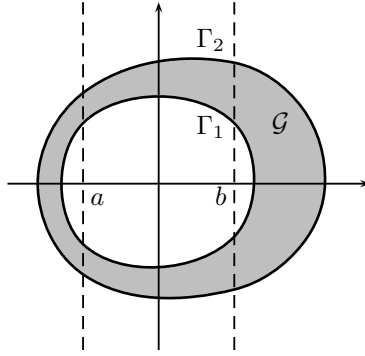
FIGURE 11. Relative positions between  $\Gamma_1$  and  $\Gamma_2$ 

$\Gamma_2 - \Gamma_1$ . So we decompose  $\mathcal{G}$  into four different regions  $\mathcal{G}_i$ ,  $i = 1, \dots, 4$ . In each region, we use the solutions to write the different time reparametrizations as follows

$$dt = \begin{cases} \frac{1}{y\varphi'(y)} dx & \text{if } (x, y) \in \mathcal{G}_1 \cup \mathcal{G}_3, \\ -\frac{1}{g(x) + f(x)\psi(y)} dy & \text{if } (x, y) \in \mathcal{G}_2 \cup \mathcal{G}_4. \end{cases}$$

See the regions  $\mathcal{G}_i$  in Figure 12.

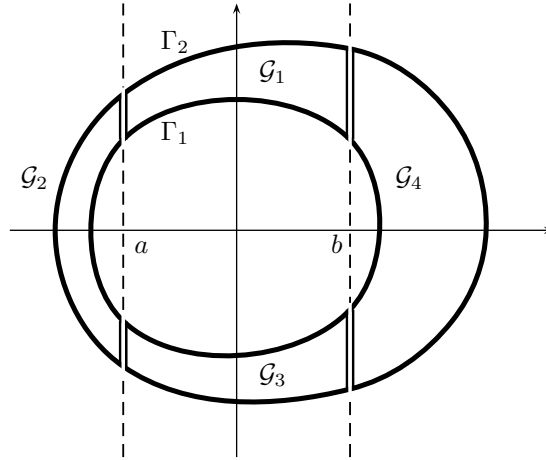
FIGURE 12. Decomposition of  $\mathcal{G}$ .

Therefore the integral (11) can be written as

$$\begin{aligned} & \iint_{\mathcal{G}_1 \cup \mathcal{G}_3} -\frac{d}{dy} \left( \frac{f(x)\psi'(y)}{y\varphi'(y)} \right) dx dy + \iint_{\mathcal{G}_2 \cup \mathcal{G}_4} \frac{d}{dx} \left( -\frac{f(x)\psi'(y)}{g(x) + f(x)\psi(y)} \right) dx dy \\ &= \iint_{\mathcal{G}_1 \cup \mathcal{G}_3} -f(x) \frac{d}{dy} \left( \frac{\psi'(y)}{y\varphi'(y)} \right) dx dy + \iint_{\mathcal{G}_2 \cup \mathcal{G}_4} -\psi'(y) \frac{g(x)^2}{(g(x) + f(x)\psi(y))^2} \frac{d}{dx} \left( \frac{f(x)}{g(x)} \right) dx dy. \end{aligned}$$

From the statements, it can be checked that the integrands of the previous expression are negative in each region where they are considered. Therefore the integral (11) is negative as we wanted to show.

Finally, we show that a semistable limit cycle,  $\Gamma$ , can not exist. We prove it by contradiction. Assume that it exists. We have already proved that the straight line

$x = a < 0$  intersects  $\Gamma$ . Take  $\bar{f}(x) = f(x) - \alpha r(x)$ , where

$$r(x) = \begin{cases} 0, & \text{if } x \geq a, \\ x - a, & \text{if } x < a < 0, \end{cases}$$

and  $0 \leq a \ll 1$ . Clearly  $\bar{f}(x)$  satisfies the assumptions of the theorem. Consider the system

$$\begin{cases} \dot{x} = y\varphi'(y), \\ \dot{y} = -g(x) - \bar{f}(x)\psi(y). \end{cases} \quad (12)$$

Then,  $Y = (\dot{x}, \dot{y})$  in (12) are generalized rotated vector fields with parameter  $\alpha$ , since

$$\begin{vmatrix} Y_1 & Y_2 \\ \frac{dY_1}{d\alpha} & \frac{dY_2}{d\alpha} \end{vmatrix} = \begin{vmatrix} y\varphi'(y) & -g(x) - \bar{f}(x)\psi(y) \\ 0 & -r(x)\psi(y) \end{vmatrix} = -y\psi(y)\varphi'(y)r(x) \geq 0$$

for any  $x$  and  $y$ , see for instance [19]. We remark that if  $\alpha = 0$  then system (12) is exactly system (4). Hence Theorem 3.4 in Chapter IV in [19] implies that when  $0 < \alpha \ll 1$ , the semistable cycle  $\Gamma$  of (4) splits into at least two cycles  $\bar{\Gamma}_2 \supset \bar{\Gamma}_1$  for (12). Furthermore,  $\bar{\Gamma}_1$  is internally stable, while  $\bar{\Gamma}_2$  is externally unstable. But from the previous step we know that coexistence of two limit cycles with different stabilities with no other periodic trajectories between them is not possible. This contradiction concludes the proof.

#### ACKNOWLEDGEMENTS

The first and second authors are supported by the MINECO MTM2013-40998-P grant. The first author is also supported by a PNPD/CAPES grant. The second author is also supported by the MINECO/FEDER UNAB13-4E-1604, the Generalitat de Catalunya 2014SGR568 and by the European Community FP7-PEOPLE-2012-IRSES-318999 and FP7-PEOPLE-2012-IRSES-316338 grants. The third author is supported by MINECO/FEDER MTM2014-52232-P and FQM-1861 (Junta de Andalucía) grants.

We would like to thank the referees for their careful reading and suggestions, which helped us to improve the paper.

#### REFERENCES

- [1] C. Bereanu, P. Jebelean, and J. Mawhin. Periodic solutions of pendulum-like perturbations of singular and bounded  $\phi$ -Laplacians. *J. Dynam. Differential Equations*, 22(3):463–471, 2010.
- [2] E. A. Coddington and N. Levinson. *Theory of ordinary differential equations*. McGraw-Hill Book Company, Inc., New York-Toronto-London, 1955.
- [3] P. De Maesschalck and F. Dumortier. Bifurcations of multiple relaxation oscillations in polynomial Liénard equations. *Proc. Amer. Math. Soc.*, 139(6):2073–2085, 2011.
- [4] Z. Došlá, M. Cecchi, and M. Marini. Asymptotic problems for differential equations with bounded  $\Phi$ -Laplacian. *Electron. J. Qual. Theory Differ. Equ.*, (Special Edition I):No. 9, 18, 2009.
- [5] L. Gold. Note on the relativistic harmonic oscillator. *J. Franklin Inst.*, 264:25–27, 1957.
- [6] H. Goldstein. *Classical mechanics*. Addison-Wesley Publishing Co., Reading, Mass., second edition, 1980. Addison-Wesley Series in Physics.
- [7] J. Guckenheimer and P. Holmes. *Nonlinear oscillations, dynamical systems, and bifurcations of vector fields*, volume 42 of *Applied Mathematical Sciences*. Springer-Verlag, New York, 2002. Revised and corrected reprint of the 1983 original.
- [8] N. Levinson and O. K. Smith. A general equation for relaxation oscillations. *Duke Math. J.*, 9:382–403, 1942.
- [9] C. Li and J. Llibre. Uniqueness of limit cycles for Liénard differential equations of degree four. *J. Differential Equations*, 252(4):3142–3162, 2012.
- [10] R. Manásevich and S. Sedziwy.  $p$ -Laplacian and Lienard-type equation. *Rocky Mountain J. Math.*, 27(2):611–617, 1997.

- [11] R. E. Mickens. Periodic solutions of the relativistic harmonic oscillator. *J. Sound Vibration*, 212(5):905–908, 1998.
- [12] B. v. d. Pol. On “relaxation-oscillations”. *Philosophical Magazine*, 2(11):978–992, 1926.
- [13] G. Sansone. Sopra l’equazione di A. Liénard delle oscillazioni di rilassamento. *Ann. Mat. Pura Appl. (4)*, 28:153–181, 1949.
- [14] P. J. Torres. Periodic oscillations of the relativistic pendulum with friction. *Physics Letters A*, 372(42):6386–6387, 2008.
- [15] P. J. Torres. Nondegeneracy of the periodically forced Liénard differential equation with  $\phi$ -Laplacian. *Commun. Contemp. Math.*, 13(2):283–292, 2011.
- [16] G. Villari. Periodic solutions of Liénard’s equation. *J. Math. Anal. Appl.*, 86(2):379–386, 1982.
- [17] G. Villari. On the existence of periodic solutions for Liénard’s equation. *Nonlinear Anal.*, 7(1):71–78, 1983.
- [18] Y. Q. Ye, S. L. Cai, L. S. Chen, K. C. Huang, D. J. Luo, Z. E. Ma, E. N. Wang, M. S. Wang, and X. A. Yang. *Theory of limit cycles*, volume 66 of *Translations of Mathematical Monographs*. American Mathematical Society, Providence, RI, second edition, 1986. Translated from the Chinese by Chi Y. Lo.
- [19] Z. F. Zhang, T. R. Ding, W. Z. Huang, and Z. X. Dong. *Qualitative theory of differential equations*, volume 101 of *Translations of Mathematical Monographs*. American Mathematical Society, Providence, RI, 1992. Translated from the Chinese by Anthony Wing Kwok Leung.

DEPARTAMENTO DE MATEMÁTICA, UNIVERSIDADE ESTADUAL PAULISTA JÚLIO DE MESQUITA FILHO, RUA CRISTOVÃO COLOMBO, 2265 15054-000 SÃO JOSÉ DO RIO PRETO. SP BRAZIL  
*E-mail address:* setperez@mat.uab.cat

DEPARTAMENT DE MATEMÀTIQUES, UNIVERSITAT AUTÒNOMA DE BARCELONA, EDIFICI C 08193 BELLATERRA, BARCELONA. SPAIN  
*E-mail address:* torre@mat.uab.cat

DEPARTAMENTO DE MATEMÁTICA APLICADA, UNIVERSIDAD DE GRANADA, 18071 GRANADA. SPAIN  
*E-mail address:* ptorres@ugr.es